

GARMIN®

FORCE[®] KRAKEN

Owner's Manual

© 2023 Garmin Ltd. or its subsidiaries

All rights reserved. Under the copyright laws, this manual may not be copied, in whole or in part, without the written consent of Garmin. Garmin reserves the right to change or improve its products and to make changes in the content of this manual without obligation to notify any person or organization of such changes or improvements. Go to www.garmin.com for current updates and supplemental information concerning the use of this product.

Garmin®, the Garmin logo, ActiveCaptain®, and Force® are trademarks of Garmin Ltd. or its subsidiaries, registered in the USA and other countries. These trademarks may not be used without the express permission of Garmin.

Wi-Fi® is a registered mark of Wi-Fi Alliance Corporation.

Table of Contents

Getting Started	1	Reverse Thrust	16
Deploying the Motor from the Stowed Position.....	1	Shifting Between Forward and Reverse Mode.....	16
Adjusting the Depth of the Trolling Motor.....	2	Waypoints	16
Stowing the Motor from the Deployed Position.....	3	Creating a Waypoint.....	16
Operation.....	3	Navigating to a Waypoint.....	16
Trolling Motor Display Panel.....	4	Viewing Waypoint Details.....	16
Status Indicator.....	6	Editing a Waypoint Name.....	17
Setting the Bow Offset.....	6	Deleting a Waypoint.....	17
Remote Control	7	Routes	17
Remote Control Screen.....	9	Navigating a Route.....	17
Navigating the Menu.....	10	Viewing Route Details.....	17
Turning the Propeller On and Off.....	10	Editing a Route Name.....	18
Adjusting the Speed of the Motor....	10	Deleting a Route.....	18
Steering the Trolling Motor Manually..	10	Tracks	18
Gesture Controls.....	10	Saving the Active Track.....	18
Using Gesture Controls to Steer.....	11	Clearing the Active Track.....	18
Using Gesture Controls to Adjust the Heading Hold.....	11	Navigating to the Start of the Active Track.....	18
Using Gesture Controls to Adjust Your Held Position.....	11	Navigating a Saved Track.....	19
Installing Batteries in the Remote Control.....	11	Viewing Saved Track Details.....	19
Attaching a Lanyard.....	11	Editing a Saved Track Name.....	19
Calibrating the Remote Control.....	12	Deleting a Saved Track.....	19
Pairing the Remote Control.....	12	Settings	20
Pairing an Additional Remote Control.....	12	Trolling Motor Settings.....	20
Autopilot	13	Wireless Network Settings.....	20
Calibrating the Trolling Motor Compass.....	13	Battery Management Settings.....	21
Acquiring a GPS Signal.....	13	Remote Control Settings.....	21
Adjusting the Autopilot Response.....	14	Backlight Settings.....	21
Maintaining Your Speed.....	14	Connecting to a Mobile Device with the ActiveCaptain App	21
Holding Your Position.....	14	Connecting to a Chartplotter	22
Maintaining Your Heading.....	14	Connecting to a Garmin Watch	22
Changing the Heading Hold Behavior.....	15	Software Updates	22
Navigating.....	15	Updating Software with the ActiveCaptain App.....	23
Pausing and Resuming Navigation..	15	Foot Pedal	24
Stopping Navigation.....	15	Installing Batteries.....	25

Pairing the Foot Pedal..... 25
Status Indicator..... 25
Disabling the Autopilot Buttons on the
Foot Pedal..... 26

Maintenance Needs and Schedule.. 26

Lubricating the Hinge..... 27
Cleaning and Lubricating the Locking
Mechanism..... 28
Servicing the Anodes..... 28
 Servicing the Propeller Anode..... 29
 Servicing the Nose Cone Anode..... 30

Specifications..... 31

Trolling Motor..... 31
 Stowed Dimensions..... 32
 Deployed Dimensions..... 33
 Motor Thrust and Current-Draw
 Information..... 34
Remote Control..... 36
Foot Pedal..... 37
Network Interfaces and Services..... 37

Getting Started

⚠ WARNING

See the *Important Safety and Product Information* guide in the product box for product warnings and other important information.

Do not run the motor when the propeller is out of the water. Contact with the rotating propeller may result in severe injury.

Do not use the motor in areas where you or other people in the water may come into contact with the rotating propeller, which could result in severe injury.



You are responsible for the safe and prudent operation of your vessel. The autopilot features on the trolling motor are tools that enhance your capability to operate your boat. They do not relieve you of the responsibility of safely operating your boat. Avoid navigational hazards and never leave the motor controls unattended.

Learn to operate the autopilot features on calm and hazard-free open water.

Use caution when operating the trolling motor near hazards in the water, such as trees, shallow rocks, docks, pilings, and other boats.

Always disconnect the motor from the battery before handling or working with the propeller, propeller drive motor, electrical connections, or electronics enclosures to avoid serious injury or death.

⚠ CAUTION

Always keep the remote control on your person when using the trolling motor. If the operation of the trolling motor needs to be changed or stopped at any time, you can press  on the remote control or on the foot pedal, or press  on the mount to stop the propeller.

When using the autopilot features, be prepared for sudden stops, acceleration, and turns.



When stowing or deploying the motor, be aware of the risk of entrapment or pinching from moving parts, which can result in personal injury.

When stowing or deploying the motor, maintain stable footing and be aware of slick surfaces around the motor. Losing your footing while stowing or deploying the motor may result in injury.

Deploying the Motor from the Stowed Position

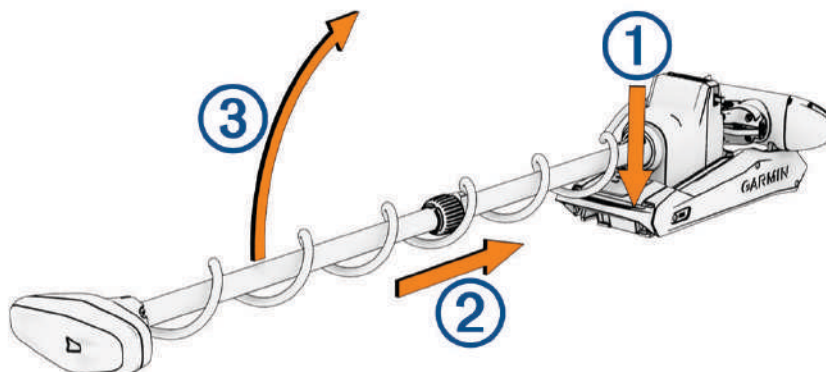
- 1 Slide the depth adjustment collar away from the motor housing.
- 2 Hold down the pedal to release the latch .



- 3 Slide the motor out , release the pedal, and raise the motor slowly  into the deployed position.
- 4 If necessary, push the shaft away to lock the motor in the deployed position.

NOTICE

The depth adjustment mechanism is keyed to align with the steering motor, and they should align automatically when you deploy the motor. To avoid unexpected steering performance, check for obstructions that may prevent the parts from aligning correctly before using the motor.

Adjusting the Depth of the Trolling Motor

- 1 Stow the motor.
- 2 Loosen the collar on the motor shaft.

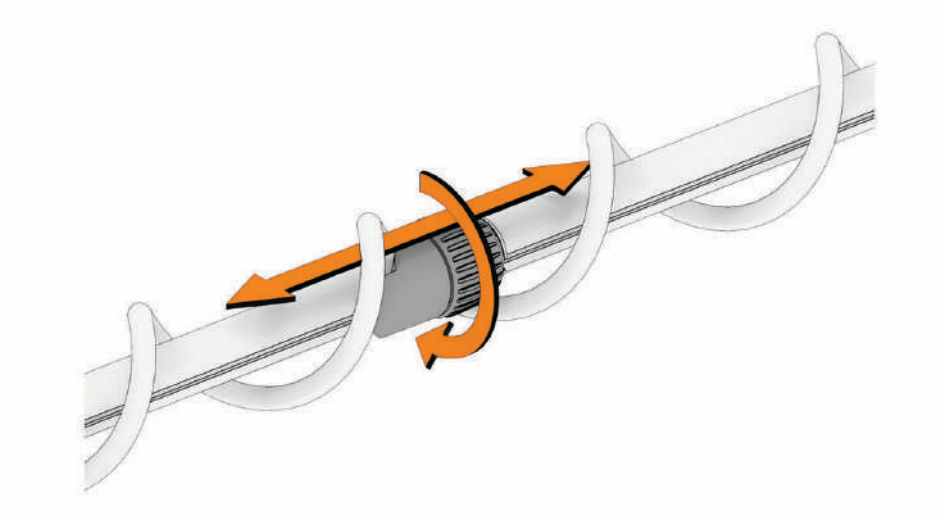

- 3 Slide the collar to raise or lower the depth of the trolling motor.
- 4 Tighten the collar.
- 5 Deploy the motor to check the depth.
- 6 Repeat this procedure if necessary to set the correct depth.

Stowing the Motor from the Deployed Position

- 1 Hold down the pedal to release the latch ①.

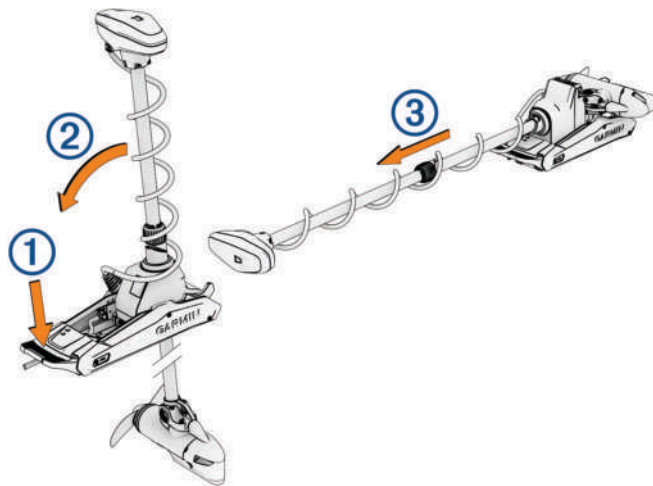

NOTE: The motor should automatically steer to 90° for stowing. The propeller stow side can be configured in the settings menu.

- 2 Tilt the shaft back ②, and then raise the motor slowly while tilting the shaft to the horizontal position.
- 3 Slide the motor into the motor catch until it locks in the stowed position ③.

⚠ WARNING

Push forward along the length of the shaft, and then pull backward along the length of the shaft to ensure that the motor is firmly locked in place. If the motor is not firmly locked in the stowed position, the motor may deploy unexpectedly while in rough waters or trailering, which could result in possible property damage or serious personal injury.

The depth adjustment collar must be moved as close to the base of the motor as possible. Failure to do so could cause unexpected trolling motor deployment, leading to potential property damage or serious personal injury.

- 4 If installed, clamp the motor shaft in the stabilizer.

Operation

You can operate every feature of the trolling motor using the included remote control (*Remote Control*, page 7).

In addition to the remote control, you can control certain features of the Force Kraken trolling motor using any of the following devices:

- the foot pedal (*Foot Pedal*, page 24) (not included).
- a mobile device with the ActiveCaptain® app (*Connecting to a Mobile Device with the ActiveCaptain App*, page 21).
- a compatible Garmin® chartplotter (*Connecting to a Chartplotter*, page 22).
- a compatible Garmin watch (*Connecting to a Garmin Watch*, page 22).

For details on controlling the trolling motor using a watch or a chartplotter, see the *Owner's Manual* for the specific device.

Trolling Motor Display Panel









⚠ CAUTION

You must keep large metallic objects, such as a tool box, away from the display panel during motor operation. Large metallic objects can interfere with the magnetic compass, affecting the built-in autopilot performance and potentially leading to personal injury or property damage.

The display panel on the trolling motor mount shows important information at a glance.

NOTE: The backlight on the display panel reacts to the ambient light, and dims automatically at night.



 Speed	Green: forward thrust speed. Red: reverse thrust speed. The number of bars represents the propeller or cruise control speed (<i>Adjusting the Speed of the Motor, page 10</i>). NOTE: You may need to update the software on your trolling motor to enable the reverse thrust feature (<i>Software Updates, page 22</i>). NOTE: In reverse thrust, the motor runs louder, produces less thrust, and is less efficient than in forward thrust.
 Trolling motor battery status	Green: the motor battery voltage level is good. Yellow: the motor battery voltage level is medium. Red: the motor battery voltage level is low. Flashing red: the motor battery voltage level is critically low. NOTE: Battery level indicators are optimized for lead-acid batteries and may be inaccurate for other types of batteries such as lithium-ion.
 GPS signal status	Green: the motor has a good GPS signal. Yellow: the motor has a poor GPS signal. Red: the motor does not have a GPS signal.
 Motor status	Green: the motor is operating normally. Red (solid): the motor software is starting up. Red (blinking): there is a system error. Blue: the motor is in pairing mode. Yellow: the motor is in recovery mode (for software updates and recovery procedures).
 Power	Press to turn the motor on or off. NOTE: By default, the trolling motor turns on automatically when it receives power. It is not necessary to push this button to turn it on. This can be changed in the settings (<i>Trolling Motor Settings, page 20</i>). The trolling motor turns off automatically when it is in the stowed position for two hours. When the propeller is turning, press to stop the propeller. Press three times to enter pairing mode.
 Propeller status	Illuminates when the propeller is active (<i>Turning the Propeller On and Off, page 10</i>).
 Heading hold status	Illuminates when heading hold is active (<i>Maintaining Your Heading, page 14</i>).
 Anchor lock status	Illuminates when anchor lock is active (<i>Holding Your Position, page 14</i>). Press to turn on anchor lock. Hold to turn off anchor lock.



Status Indicator

The  LED indicates the motor status.





Green	Normal operation
Red	Solid: system booting Blinking: system error
Blue	Pairing mode
Yellow	Recovery mode (for software updates and recovery procedures)

Setting the Bow Offset

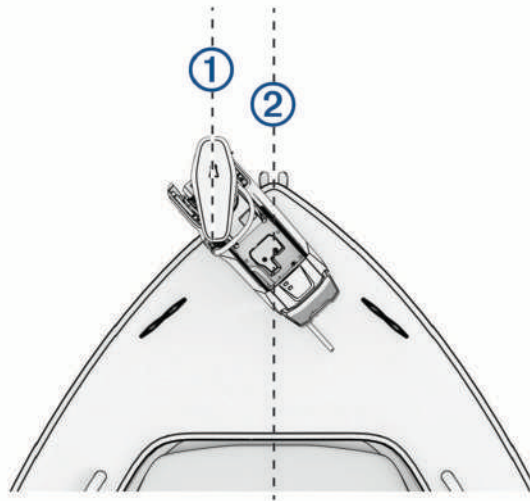
Based on the installation angle, the trolling motor may not align with the center line of your boat. For the best results, you should set the bow offset.

- 1 Using the remote control, adjust the angle of the trolling motor  so it aligns with the center line of your boat , pointing straight forward.











- 2 On the remote control, select  > **Settings** > **Trolling Motor** > **Calibrate** > **Bow Offset**.
- 3 Press  or  to adjust the bow offset.
- 4 Press  to set the bow offset.
- 5 Repeat this procedure if necessary.

Remote Control

NOTE: You may need to update the software on your trolling motor to enable the reverse thrust feature ([Software Updates, page 22](#)).





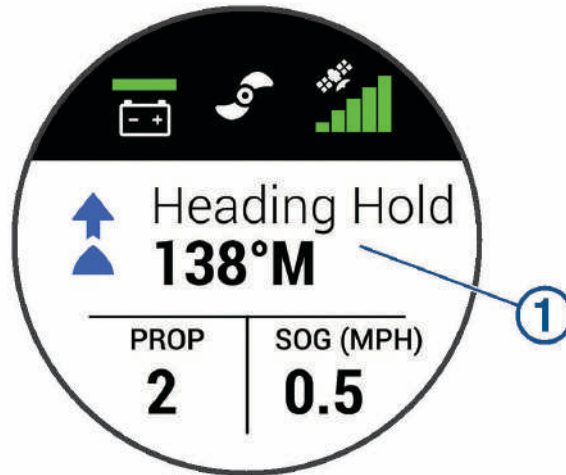

Button	Description
	Hold to turn the remote control on and off.
	Press to turn on and set cruise control at the current speed over ground (SOG) (Maintaining Your Speed, page 14). Press again to disable cruise control and return to manual speed control.
	Press twice to turn on the propeller and set it to full speed. Press again to return to the previous speed and propeller state.
	Press for manual control (Steering the Trolling Motor Manually, page 10). Hold to steer using gestures (Using Gesture Controls to Steer, page 11).
	Press once to turn the propeller on or off (Turning the Propeller On and Off, page 10). Press twice to turn off any autopilot function (if enabled), stop the propeller, and shift between forward and reverse thrust (Reverse Thrust, page 16).
	Press to navigate the menu (Navigating the Menu, page 10). When in the menu, press  to select a menu item, and press  to go back without saving. When in anchor lock, press to jog the anchor lock position forward, backward, left, or right in 1.5 m (5 ft.) increments. When in heading hold or manual control, press  and  for single-degree step turns, or hold for steering in five-degree increments. Press  and  for incremental speed changes, or hold for continuous speed changes. When your speed is set to zero, press  to shift into reverse (Reverse Thrust, page 16).
	Press to turn on heading hold. Heading hold uses the trolling motor to maintain your current heading (Maintaining Your Heading, page 14). Press again to turn off heading hold, stop the propeller, and resume manual control. Hold to set the heading hold by pointing the remote (Using Gesture Controls to Adjust the Heading Hold, page 11).
	Press to turn on anchor lock. Anchor lock uses the trolling motor to hold your position (Holding Your Position, page 14). Press again to turn off anchor lock and return to the previous steering mode. Hold to jog the anchor lock position by pointing the remote (Using Gesture Controls to Adjust Your Held Position, page 11).
	Press to open the menu. Press to exit the menu.
	Press to mark a waypoint.
1 through 4	Press to open the shortcut for the Garmin chartplotter assigned to the button. ¹

¹ Requires a connection to a compatible Garmin chartplotter. See your chartplotter owner's manual for instructions.

Remote Control Screen









<p>①</p>	<p>Shows the operational status of the trolling motor. For example, when in manual control, Manual is shown, and when the heading hold is on, Heading Hold is shown, along with the heading-hold set point in degrees.</p>
<p></p>	<p>Shows the trolling motor battery status. Green: the motor battery voltage level is good. Yellow: the motor battery voltage level is medium. Red: the motor battery voltage level is low. Flashing red: the motor battery voltage level is critically low. NOTE: By default, the battery level indicator is optimized for lead-acid batteries (Battery Management Settings, page 21). TIP: You can change the appearance of the trolling motor battery status so that it shows a numeric voltage instead of an icon (Trolling Motor Settings, page 20). You can view the remote control battery level by pressing .</p>
<p></p>	<p>Shows the status of the propeller. White and rotating: the propeller is providing a forward thrust. Red and rotating: the propeller is providing a reverse thrust.² NOTE: You may need to update the software on your trolling motor to enable the reverse thrust feature (Software Updates, page 22). Not rotating: the propeller is on with the speed set to zero. Not shown: the propeller is off.</p>
<p></p>	<p>Shows the GPS signal strength of the trolling motor.</p>
<p>PROP</p>	<p>Shows the speed level of the propeller (Adjusting the Speed of the Motor, page 10). When the propeller is actively providing a reverse thrust, the speed level is shown in red.² NOTE: The propeller speed is not shown when the motor is using cruise control.</p>
<p>SOG</p>	<p>Shows the measured speed over ground (SOG).</p>

² In reverse thrust, the motor runs louder, produces less thrust, and is less efficient than in forward thrust.

Navigating the Menu

You can use the menu and arrow keys to navigate the menu on the remote control.

- To open the menu, press .
- To move between different menu items, press  and .
- To select a menu item, press .
- To move back to a previous menu item, press .
- To exit the menu, press  or press  repeatedly until you reach the main screen.

Turning the Propeller On and Off



WARNING

Do not use the motor in areas where you or other people in the water may come into contact with the rotating propeller, which could result in severe injury.

Do not run the motor when the propeller is out of the water. Contact with the rotating propeller may result in severe injury.

- 1 If necessary, deploy the trolling motor ([Deploying the Motor from the Stowed Position, page 1](#)).

NOTE: The propeller cannot turn on when the trolling motor is in the stowed position.

- 2 On the remote control, press  to turn on the propeller.
- 3 Press  again to turn off the propeller.

Adjusting the Speed of the Motor

On the remote control, press  or  to increase or decrease your speed.

In manual mode, the propeller speed, shown in the PROP field on the remote control screen, increases or decreases accordingly.

In cruise control mode, the current target speed is displayed on the trolling motor remote screen, and it increases or decreases accordingly.

NOTE: In manual mode, increasing or decreasing the speed using the remote control does not automatically turn the propeller on. You must press the  button on the remote control to turn on the propeller.

Toggling Full Speed

- 1 On the remote control, press  twice.

The trolling motor propeller speed quickly increases to full speed.



- 2 Press  to return to the previous propeller speed.

TIP: When at full speed, you can press  on the remote control to slowly decrease the propeller speed.

Steering the Trolling Motor Manually

In manual mode, you can adjust the direction and speed of the trolling motor as needed.

NOTE: The trolling motor is in manual mode by default when you turn it on.

- 1 If necessary, press .
- 2 Press  and  to steer.



TIP: You can also use gesture controls to steer ([Using Gesture Controls to Steer, page 11](#)).

Gesture Controls

You can point or move the remote control to interact with the trolling motor. You must calibrate the compass in the trolling motor ([Calibrating the Trolling Motor Compass, page 13](#)), and the compass in the remote control ([Calibrating the Remote Control, page 12](#)) before you can use gesture controls.



Using Gesture Controls to Steer

You can steer the motor by pointing the remote control.

- 1 If necessary, turn on the propeller (*Turning the Propeller On and Off*, page 10).
- 2 Hold .
- 3 While holding , point the remote control to the left or right to steer port or starboard.
- 4 Release  to stop steering.



Using Gesture Controls to Adjust the Heading Hold

You can move the remote control to adjust your heading hold (*Maintaining Your Heading*, page 14).

- 1 If necessary, turn on the propeller (*Turning the Propeller On and Off*, page 10).
- 2 Hold .
- 3 Point the remote control toward where you want to adjust the heading.
- 4 Release  to set the heading direction.

Using Gesture Controls to Adjust Your Held Position

You can move the remote control to adjust your position when using the anchor lock feature (*Holding Your Position*, page 14).

- 1 Hold .
- 2 Point the remote control in the direction you want to move your position.
Your position jogs 1.5 m (5 ft.) in the direction you point.
- 3 Release .
- 4 Repeat this procedure until the you are in the position you want.

Installing Batteries in the Remote Control

The remote control operates using two AA batteries (not included). Use lithium batteries for best results.

- 1 Turn the D-ring counter-clockwise, and pull up to remove the cover.
- 2 Insert two AA batteries, observing polarity.
- 3 Replace the battery cover, and turn the D-ring clockwise.

Attaching a Lanyard

- 1 Starting from the back of the remote control, insert the loop of the lanyard  through the slot.

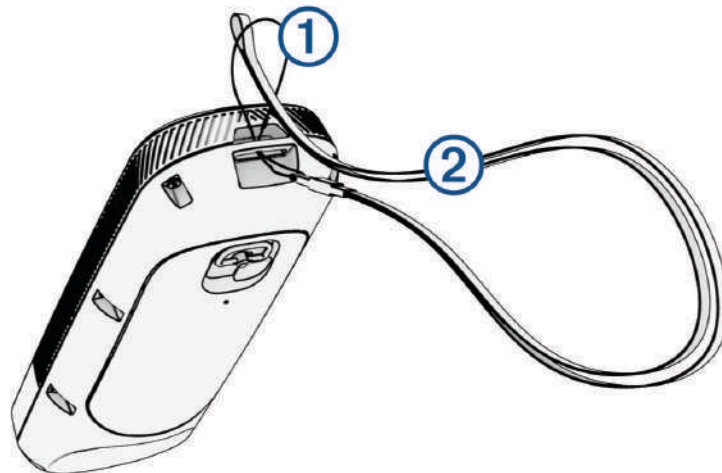

- 2 Thread the other end of the lanyard  through the loop, and pull it tight.
- 3 If necessary, place the lanyard around your neck or wrist to tether it during use.

Calibrating the Remote Control

NOTICE



Calibrate the electronic compass outdoors. To improve heading accuracy, do not stand near objects that influence magnetic fields, such as vehicles, buildings, and overhead power lines.

You must calibrate the compass in the remote control before you can control the motor using gestures. If the gesture controls are not working properly after calibration, you can repeat this process as often as needed.

- 1 Select  > **Settings** > **Remote Control** > **Calibrate**.
- 2 Select **Start**, and follow the on-screen instructions.

Pairing the Remote Control



The remote control is paired with the trolling motor at the factory. Follow these steps if you need to pair it again.

- 1 Turn on the trolling motor.
- 2 Press  on the trolling motor three times to enter pairing mode.
The  status LED on the trolling motor illuminates blue as it searches for a connection.
- 3 Bring the remote control within 1 m (3 ft.) of the trolling motor.
- 4 Turn on the remote control.
- 5 On the remote control, select  > **Settings** > **Remote Control** > **Pairing** > **Pair** > **Start**.
After a few seconds, Pairing Complete is shown on the remote control.

Pairing an Additional Remote Control

You can have up to two remote controls connected to your trolling motor at the same time.

To pair a second remote control, you must follow these steps using the first connected remote control.

- 1 Turn on the trolling motor.
- 2 On a remote control already paired to the motor, select  > **Settings** > **Remote Control** > **Pairing** > **Add Additional Remote**.
- 3 Bring the additional remote control within 1 m (3 ft.) of the display panel on the trolling motor.
- 4 Turn on the additional remote control.
- 5 On the additional remote control, select  > **Settings** > **Remote Control** > **Pairing** > **Pair** > **Start**.
Device Found appears on the first remote control. After a few seconds, Pairing Complete appears on the second remote control.

Autopilot

⚠ WARNING

You are responsible for the safe and prudent operation of your vessel. The autopilot features on the trolling motor are tools that enhance your capability to operate your boat. They do not relieve you of the responsibility of safely operating your boat. Avoid navigational hazards and never leave the motor controls unattended.

Learn to operate the autopilot features on calm and hazard-free open water.

⚠ CAUTION

When using the autopilot features, be prepared for sudden stops, acceleration, and turns.

The Force Kraken trolling motor supports autopilot features such as following a pre-planned route, maintaining your heading, and holding your position.

You must calibrate the trolling motor compass before you can use the autopilot features (*Calibrating the Trolling Motor Compass, page 13*). You must have a GPS signal to activate an autopilot mode (*Acquiring a GPS Signal, page 13*).

You can activate and control every autopilot mode using the included remote control (*Remote Control, page 7*). You can control certain autopilot features using other compatible devices (*Operation, page 3*).

TIP: In some situations, the autopilot modes can create more turbulence than expected. You can adjust the autopilot gain settings to tailor the autopilot sensitivity to different conditions (*Adjusting the Autopilot Response, page 14*).

The Force Kraken supports the following autopilot features:

Cruise Control: The motor automatically controls the propeller speed to maintain a target speed (*Maintaining Your Speed, page 14*).

Anchor Lock: The motor automatically steers and runs the propeller to maintain your position (*Holding Your Position, page 14*).

Heading Hold: The motor steers automatically to keep your boat in the same heading (*Maintaining Your Heading, page 14*).

Route Following: The motor can steer and run the propeller automatically to navigate to a waypoint or along a course or a track (*Navigating, page 15*).

Calibrating the Trolling Motor Compass

Before calibrating the trolling motor compass, you must move to an open area of calm water, with enough space to maneuver the boat in a circle.

NOTICE

Calibrating the trolling motor compass in rough water and wind conditions may negatively affect autopilot performance.

1 Make sure the trolling motor is in the deployed position (*Deploying the Motor from the Stowed Position, page 1*).

2 On the remote control, select  > **Settings** > **Trolling Motor** > **Calibrate** > **Compass**.

3 When prompted, follow the on-screen instructions to calibrate the compass.

You can use a foot pedal, remote control, or outboard motor to steer the boat while calibrating the compass..

If the autopilot features do not perform as expected, you should repeat the calibration process.

Acquiring a GPS Signal





1 Move the boat to an area with an unobstructed view of the sky.

2 Wait 30 to 60 seconds while the trolling motor locates satellites.

When the motor has acquired a position using GPS, the  LED indicator light is solid green.

Adjusting the Autopilot Response

You can adjust the autopilot gain setting to tailor the autopilot sensitivity to different conditions.

- 1 On the remote control, select  > **Settings** > **Trolling Motor**.
- 2 Select an option:
 - To adjust the gain for Anchor Lock mode, select **Anchor Gain**.
 - To adjust the autopilot gain for navigation modes, including Heading Hold and Cruise Control, select **Navigation Gain**.
- 3 Select  or  to increase or decrease the gain value:
 - Increase the gain setting to make the autopilot more responsive. The motor will be more accurate in controlling your boat, but it may create more turbulence. Higher gain values are typically needed for larger or heavier boats.
 - Decrease the gain setting to make the autopilot less responsive. The motor will create less turbulence, but it may be less accurate in controlling your boat.
- 4 Select  to confirm your selection.

Maintaining Your Speed

Before you can use autopilot features, you must calibrate the trolling motor ([Calibrating the Trolling Motor Compass, page 13](#)).

The cruise control feature is an autopilot function that sets and maintains a specific speed over ground, adjusting for changes in current and wind automatically.

TIP: You can use cruise control alongside other autopilot modes ([Autopilot, page 13](#)).

On the remote control, press .

Cruise control is enabled at the present speed.

To turn off cruise control and turn off the propeller, you must press .

Holding Your Position

Before you can use autopilot features, you must calibrate the trolling motor ([Calibrating the Trolling Motor Compass, page 13](#)).

The anchor lock feature uses GPS to maintain your position using the trolling motor.

Press .

NOTE: You can adjust the anchor lock position by pressing an arrow key on the remote control, or by using gesture controls ([Using Gesture Controls to Adjust Your Held Position, page 11](#)).

To disable anchor lock, press  again.



Maintaining Your Heading

Before you can use autopilot features, you must calibrate the trolling motor ([Calibrating the Trolling Motor Compass, page 13](#)).



You can activate Heading Hold to keep your boat moving in the same compass direction. The motor may adjust your heading automatically to compensate for drift caused by factors such as wind and currents.

1 Steer the boat in the direction you want to go.

2 Press .

NOTE: You can adjust the direction by pressing  and , or by using gesture controls ([Using Gesture Controls to Adjust the Heading Hold, page 11](#)).

TIP: While using this autopilot mode, you can also maintain your speed using cruise control ([Maintaining Your Speed, page 14](#)).

To disable Heading Hold and return to manual mode, you must select  or .

Changing the Heading Hold Behavior

By default, the Heading Hold feature is set to Go To mode, which may adjust your heading to compensate for drift and keep your boat moving in the same direction. If preferred, you can configure the Heading Hold feature to use Vessel Align mode, which ignores drift and simply keeps the bow of your boat pointing in the same direction.

- 1 On the remote control, select  > **Settings** > **Trolling Motor** > **Heading Hold**.
- 2 Select **Vessel Align**.

You can select Go To to revert back to the default Heading Hold behavior.

Navigating

Before you can use autopilot features, you must calibrate the trolling motor ([Calibrating the Trolling Motor Compass, page 13](#)).

The trolling motor uses GPS to steer the boat to a waypoint location or to follow a route or a track.

- 1 On the remote control, select an option:
 - Begin navigating to a saved waypoint ([Navigating to a Waypoint, page 16](#)).
 - Begin navigating a saved route ([Navigating a Route, page 17](#)).
 - Begin retracing the active track ([Navigating to the Start of the Active Track, page 18](#)).
 - Begin navigating a saved track ([Navigating a Saved Track, page 19](#)).



NOTE: You can also use the trolling motor to follow autoguidance paths when navigation is started from a connected chartplotter. See your chartplotter owner's manual for more information.

Navigating is shown on the remote control screen, and the trolling motor automatically steers the boat to the destination.



- 2 Adjust the speed as needed.

TIP: While using this autopilot mode, you can also maintain your speed using cruise control ([Maintaining Your Speed, page 14](#)).

Pausing and Resuming Navigation

- 1 While navigating, on the remote control, select an option:
 - To pause navigation while continuing in the same direction at the same speed, select  > **Standby**.
 - To pause navigation and set anchor lock, select 

Navigation stops, and the trolling motor returns to manual mode or maintains your position in anchor lock.

- 2 Select  > **Follow Route** or press  to resume navigation.
- 3 If necessary, start the propeller.

Stopping Navigation

Select  > **Stop Nav**.

Navigation stops, and the trolling motor returns to manual mode.

Reverse Thrust

NOTE: You may need to update the software on your trolling motor to enable the reverse thrust feature ([Software Updates, page 22](#)).

In manual mode, you can run the propeller in reverse. Running the propeller in reverse for short periods of time can be useful in some situations, such as backing out of a tight space with less steering of the motor.

Because the propeller on the trolling motor is designed primarily for forward thrust, it is less efficient at creating reverse thrust, resulting in more noise from the motor, especially at higher propeller speeds, and more turbulence underwater.

NOTICE

You should use reverse thrust sparingly to minimize cavitation and excessive wear on the propeller and the propeller drive motor.

Shifting Between Forward and Reverse Mode

- 1 Press  twice.

The  icon on the remote control screen turns red when the propeller is set to reverse. If the motor is running in an autopilot mode, it automatically switches to manual mode. If the propeller is running, it automatically stops.

- 2 Press  again to turn the propeller on.

NOTE: When shifting between forward and reverse mode, the propeller speed is automatically set to the last speed you used in the same thrust mode.

Waypoints

Waypoints are used to mark locations so you can return to them later. The trolling motor can store up to 5000 waypoints.

When the trolling motor is connected to a chartplotter, the waypoints stored on the trolling motor and on the chartplotter are automatically synchronized.

NOTE: Because the systems are synchronized, when you delete waypoints, restore default settings, or clear user data using the trolling motor remote, the waypoints on the chartplotter are also deleted. Likewise, if you delete a waypoint from the chartplotter, it is automatically deleted from the trolling motor.

Creating a Waypoint

You can save your current location as a waypoint.

- 1 If necessary, drive to a location you want to save as a waypoint.
- 2 On the remote control, press .

Navigating to a Waypoint

- 1 On the remote control, select  > **Waypoints**.
A list of the ten closest waypoints is shown.
- 2 Select a waypoint.
- 3 Select **Navigate To**.
- 4 Turn on the propeller ([Turning the Propeller On and Off, page 10](#)).
The trolling motor drives to the waypoint location ([Navigating, page 15](#)).

Viewing Waypoint Details

- 1 On the remote control, select  > **Waypoints**.
A list of the ten closest waypoints is shown.
- 2 Select a waypoint.
- 3 Select **Review**.

Editing a Waypoint Name

- 1 On the remote control, select  > **Waypoints**.
A list of the ten closest waypoints is shown.
- 2 Select a waypoint.
- 3 Select **Edit**.
- 4 Enter a new name for the waypoint.

Deleting a Waypoint

- 1 On the remote control, select  > **Waypoints**.
A list of the ten closest waypoints is shown.
- 2 Select a waypoint.
- 3 Select **Delete**.

Routes

A route is a sequence of locations that leads you to your final destination.

When you connect the trolling motor to a chartplotter, the routes stored on the chartplotter are synchronized with the routes stored on the trolling motor. Deleting or editing routes on one device automatically changes the routes stored on the other device. You can create routes on the chartplotter only.

You can save up to 100 routes.

Navigating a Route

- 1 On the remote control, select  > **Routes**.
A list of the ten closest routes is shown.
- 2 Select a route.
- 3 Select **Navigate To**.
- 4 Select an option:
 - To navigate the route from the starting point used when the route was created, select **Forward**.
 - To navigate the route from the destination point used when the route was created, select **Backward**.
 - To navigate from your current location to the beginning of the route, then navigate the route, select **From Start**.
- 5 Turn on the propeller ([Turning the Propeller On and Off, page 10](#)).
The trolling motor drives along the route in the chosen direction ([Navigating, page 15](#)).

As you approach the end of the route, by default, the trolling motor switches to the anchor lock feature and holds position at the end of the route. You can change this behavior in the settings ([Trolling Motor Settings, page 20](#)).

Viewing Route Details

- 1 On the remote control, select  > **Routes**.
A list of the ten closest routes is shown.
- 2 Select a route.
- 3 Select **Review**.

Editing a Route Name

- 1 On the remote control, select  > **Routes**.
A list of the ten closest routes is shown.
- 2 Select a route.
- 3 Select **Edit**.
- 4 Enter a new name for the route.

Deleting a Route

- 1 On the remote control, select  > **Routes**.
A list of the ten closest routes is shown.
- 2 Select a route.
- 3 Select **Delete**.

Tracks

A track is a recording of the path of your boat. The track currently being recorded is called the active track, and it can be saved. You can save up to 50 tracks.

When you connect the trolling motor to a chartplotter, the active track and saved tracks stored on the chartplotter are synchronized with the active track and saved tracks stored on the trolling motor. Adding, deleting, or editing active and saved tracks on one device automatically changes the active and saved tracks stored on the other device.

Saving the Active Track

The track currently being recorded is called the active track. You can save the active track and navigate it later. You can save up to 50 tracks on the trolling motor.

- 1 On the remote control, select  > **Tracks** > **Save Active Track**.
The active track is saved with the current date as the track name.
- 2 Change the name for the saved track (optional).

Clearing the Active Track

Select  > **Tracks** > **Clear Active Track**.

The track memory is cleared, and the active track continues to be recorded.

Navigating to the Start of the Active Track

The track currently being recorded is called the active track. You can navigate from your current position back to the starting point of the active track along the path you traveled.

- 1 Select  > **Tracks** > **Backtrack**.
- 2 Turn on the propeller (*Turning the Propeller On and Off, page 10*).
The trolling motor navigates back to the starting point of the active track along the path you traveled (*Navigating, page 15*).

Navigating a Saved Track

- 1 Select  > **Tracks** > **Saved Tracks**.

A list of the ten closest saved tracks is shown.

- 2 Select a saved track.
- 3 Select **Navigate To**.
- 4 Select an option:
 - To navigate the saved track from the beginning of the track to the end, select **Forward**.
 - To navigate the saved track from the end of the track back to the beginning, select **Backward**.
- 5 Turn on the propeller ([Turning the Propeller On and Off, page 10](#)).
The trolling motor drives along the saved track in the chosen direction ([Navigating, page 15](#)).

Viewing Saved Track Details

- 1 On the remote control, select  > **Tracks** > **Saved Tracks**.
A list of the ten closest saved tracks is shown.
- 2 Select a saved track.
- 3 Select **Review**.

Editing a Saved Track Name

- 1 On the remote control, select  > **Tracks** > **Saved Tracks**.
A list of the ten closest saved tracks is shown.
- 2 Select a saved track.
- 3 Select **Edit**.
- 4 Enter a new name for the saved track.

Deleting a Saved Track

- 1 On the remote control, select  > **Tracks** > **Saved Tracks**.
A list of the ten closest saved tracks is shown.
- 2 Select a saved track.
- 3 Select **Delete**.

Settings

Trolling Motor Settings

On the remote control, select  > **Settings** > **Trolling Motor**.

Wi-Fi: Sets the wireless network preferences for the trolling motor ([Wireless Network Settings, page 20](#)).

Calibrate: Calibrates the trolling motor compass ([Calibrating the Trolling Motor Compass, page 13](#)) and sets the trolling motor bow offset ([Setting the Bow Offset, page 6](#)).

Units: Sets the units of measure.

Battery Management: Defines settings related to the trolling motor battery ([Battery Management Settings, page 21](#)).

Beeper: Disables or enables the autopilot notification beeps.

Prop Stow Side: Sets which side of the trolling motor the propeller rotates to when stowing the trolling motor. This is helpful when you store other items near the stowed propeller. This may also be necessary if you install a LiveScope™ transducer on the trolling motor.

Auto Power On: Turns on the trolling motor when you apply power to the system.

Heading Hold: Sets the behavior of the heading hold feature ([Changing the Heading Hold Behavior, page 15](#)).

Nav. Arrival: Sets the behavior of the trolling motor when you reach the end of a route. With the Anchor Lock setting, the trolling motor holds the position using the anchor lock feature when the boat reaches the end of the route. With the Manual setting, the propeller turns off when the boat reaches the end of the route.

CAUTION

When using Manual for the Nav. Arrival setting, you must be ready to take control of the boat.

Anchor Gain: Sets the level of autopilot response when in anchor lock mode ([Adjusting the Autopilot Response, page 14](#)).

Navigation Gain: Sets the level of autopilot response when in other autopilot modes ([Adjusting the Autopilot Response, page 14](#)).

Clear User Data: Deletes all saved waypoints, routes, tracks, and your active track.

NOTE: If you are connected to a chartplotter, selecting this clears user data from both the trolling motor and the connected chartplotter.

Restore Defaults: Resets the trolling motor settings to the factory default values.

NOTE: Restoring default settings does not clear user data on the trolling motor or on a connected chartplotter.

Clear Diagnostics: Deletes system-generated data that is stored on the trolling motor for troubleshooting purposes.

Wireless Network Settings

On the remote control, select  > **Settings** > **Trolling Motor** > **Wi-Fi**.

NOTE: The active Wi-Fi® mode is shown at the top of the screen.

Mode: Sets the Wi-Fi mode. You can turn off Wi-Fi technology, join the network of a chartplotter, or create a wireless access point to use the ActiveCaptain app ([Connecting to a Mobile Device with the ActiveCaptain App, page 21](#)).

Setup > Name: Sets the name of the wireless access point on the trolling motor (ActiveCaptain mode only).

Setup > Password: Sets the password for the wireless access point on the trolling motor (ActiveCaptain mode only).

Battery Management Settings

On the remote control, select  > **Settings** > **Trolling Motor** > **Battery Management**.

Indicator: Sets the appearance of the trolling motor battery indicator to either an icon or a numeric voltage value.

Battery Setup: Sets the type of battery connected to the trolling motor, which helps calculate the reported battery status.

Remote Control Settings

On the remote control, select  > **Settings** > **Remote Control**.

Backlight: Adjusts the backlight settings. (*Backlight Settings, page 21*)

Beeper: Sets the beeper to sound for key presses and alarms.

Auto Power Off: Sets the length of time before the remote control turns off automatically.

Calibrate: Calibrates the remote control for the gesture-control features (*Calibrating the Remote Control, page 12*).

Pairing: Pairs the remote control with the trolling motor (*Pairing the Remote Control, page 12*).

Language: Sets the on-screen text language.

Restore Defaults: Resets the remote control to factory default settings. This restores the default configuration settings on the remote control, but does not remove saved user data.

Backlight Settings

On the remote control, select  > **Settings** > **Remote Control** > **Backlight**.

Keys: Sets the backlight to turn on when a key is pressed.

Alarms: Sets the backlight to turn on when an alarm sounds on the remote control.

Timeout: Sets the length of time before the backlight turns off.

Brightness: Sets the brightness level of the backlight.

Connecting to a Mobile Device with the ActiveCaptain App

You can connect a mobile device to the trolling motor using the ActiveCaptain app. The app provides a quick and easy way for you to interact with your trolling motor and update the device software.



- 1 On the remote control, select  > **Settings** > **Trolling Motor** > **Wi-Fi** > **Mode** > **ActiveCaptain** > **Setup**.
- 2 Enter a name and password for this network.
- 3 From the application store on your mobile device, install and open the ActiveCaptain app.
- 4 Bring the mobile device near the trolling motor.
- 5 From your mobile device settings, open the Wi-Fi connections page and connect to the trolling motor, using the name and password you entered in the previous step.

Connecting to a Chartplotter

Your compatible Garmin chartplotter must have the latest software version installed before you can connect the trolling motor.

NOTE: You can check the list of compatible Garmin devices at garmin.com/force_kraken/compatible to make sure your chartplotter supports the trolling motor.

You can connect the trolling motor wirelessly to a compatible Garmin chartplotter. After you connect to a compatible chartplotter, you can control the trolling motor from the chartplotter.



- 1 Turn on the chartplotter and the trolling motor.
- 2 Make sure that the chartplotter is hosting a wireless network.
NOTE: If you have multiple chartplotters installed, only one is the wireless network host. Consult your chartplotter's owner's manual for more information.
- 3 On the chartplotter, select **Settings > Communications > Wireless Devices > Garmin Trolling Motor > Start**.
- 4 On the trolling motor display panel, press  three times to enter pairing mode.
The  LED indicator light on the trolling motor illuminates blue as it searches for a connection to the chartplotter, and changes to green when the connection is successful.
A confirmation message appears on the chartplotter when the connection is successful.
- 5 After the chartplotter and trolling motor connect successfully, enable the trolling motor bar on the chartplotter to control the motor.
See the latest version of your chartplotter's owner's manual for complete operation instructions.

Connecting to a Garmin Watch

You can connect the trolling motor wirelessly to a compatible Garmin watch, and control the trolling motor using the Trolling Motor app on the watch.

NOTE: You can check the list of compatible Garmin devices at garmin.com/force_kraken/compatible to make sure your watch supports the trolling motor.

The first time you connect the trolling motor to your watch, you must pair the watch and the motor. After they are paired, the watch connects to the motor automatically when the motor is powered on and within range.

- 1 Make sure the trolling motor is powered on and a remote control is connected to it.
- 2 Bring your compatible Garmin watch within 3 m (10 ft.) of the trolling motor.
- 3 On the watch, hold **MENU**.
- 4 Select **Sensors & Accessories > Add New > Trolling Motor**.
- 5 On the trolling motor display panel, press  three times to enter pairing mode.
 on the trolling motor display panel is solid blue as it searches for a connection, and changes to solid green when the connection is successful.
- 6 Confirm the pairing code shown on the watch and on the connected remote control.

You can press **START** and select Trolling Motor from the list of activities and apps to open the trolling motor controls.

Software Updates

You can go to garmin.com/support/software/marine.html to find information on the latest software updates for your Garmin marine devices.

Updating Software with the ActiveCaptain App

You can go to garmin.com/videos/trolling_motor_update/ and watch a video to assist with the software-update process.

NOTICE

Software updates may require the app to download large files. Regular data limits or charges from your internet service provider apply. Contact your internet service provider for more information about data limits or charges.

The installation process will take several minutes.

NOTE: To update the trolling motor, you must connect your mobile device directly to a dedicated Wi-Fi network on the trolling motor using the ActiveCaptain app.



- 1 If necessary, set up the trolling motor for use with the ActiveCaptain app (*Connecting to a Mobile Device with the ActiveCaptain App*, page 21).
- 2 Connect the mobile device to the dedicated Wi-Fi network on the trolling motor.
Connecting to the Wi-Fi network on the trolling motor provides the app with the information needed to download the appropriate update files.
- 3 Open the ActiveCaptain app.
- 4 Disconnect the mobile device from the dedicated Wi-Fi network on the trolling motor.
- 5 Connect the mobile device to the internet.
- 6 From the ActiveCaptain app, select **My Marine Devices > Download**.
NOTE: The option to download an update is shown only if a software update is available for your device. The ActiveCaptain app downloads the update to the mobile device.
- 7 Reconnect the mobile device to the dedicated Wi-Fi network on the trolling motor.
The update is transferred to the trolling motor. This could take up to 30 minutes to complete. The motor speed indicator lights on the trolling motor display panel blink to indicate that the software is updating.
NOTE: If the transfer is complete but the trolling motor display panel lights do not start blinking, you should turn off the trolling motor and turn it back on to run the update.
- 8 Make sure the remote control is turned on and connected.
After the trolling motor software update is complete, if an update for the remote control is available, the speed indicator lights blink, and a countdown begins on the remote control. At the end of the countdown, the remote control displays  while it completes the update process. This could take up to 5 minutes to complete.
- 9 Make sure the foot pedal is turned on and connected.
After the trolling motor software update is complete, if an update for the foot pedal is available, the indicator light on the foot pedal illuminates purple while it completes the update process. When the indicator light turns off, the update is complete.

Foot Pedal

You can control the trolling motor using the foot pedal (sold separately).

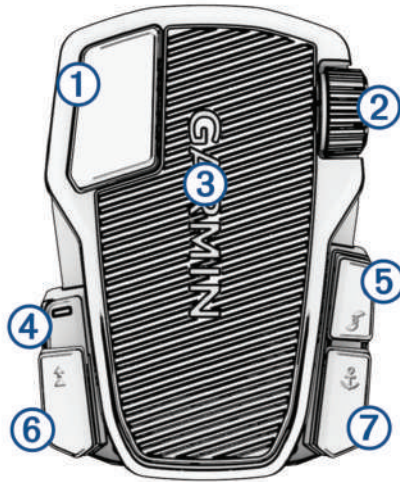
NOTE: You may need to update the software on your trolling motor to enable the reverse thrust feature ([Software Updates](#), page 22).



①	Momentary propeller control	Hold to turn on the propeller at the set speed. Release to turn off the propeller.
②	Speed wheel	Rotate the wheel away from you to increase the propeller speed or cruise control speed. Rotate the wheel toward you to decrease the propeller speed or cruise control speed. NOTE: The speed wheel is inactive when anchor lock is on.
③	Steering pedal	Push the pedal with your toes to turn the motor clockwise. Push the pedal with your heel to turn the motor counter-clockwise. NOTE: When anchor lock or heading hold is on, or you are following a route, tilt the pedal or press a button to resume manual control at the previous propeller speed.
④	Status LED	Shows the status of the foot pedal (Status Indicator , page 25).
⑤	Continuous propeller control 	Press once to turn the propeller on or off (Turning the Propeller On and Off , page 10). Press twice to turn off any autopilot function (if enabled), stop the propeller, and shift between forward and reverse thrust (Reverse Thrust , page 16).
⑥	Heading hold 	Press once to set and maintain the current heading (Maintaining Your Heading , page 14). Press again to turn off heading hold, stop the propeller, and resume manual control. Press twice to turn off any autopilot function (if enabled), stop the propeller, and shift between forward and reverse thrust (Reverse Thrust , page 16). TIP: You can disable this button by pressing it six times. You can press it six times again to re-enable it.
⑦	Anchor lock 	Press to turn on anchor lock. Anchor lock uses the trolling motor to hold your position (Holding Your Position , page 14). Press again to turn off anchor lock and return to the previous steering mode. TIP: You can disable this button by pressing it six times. You can press it six times again to re-enable it.

Installing Batteries



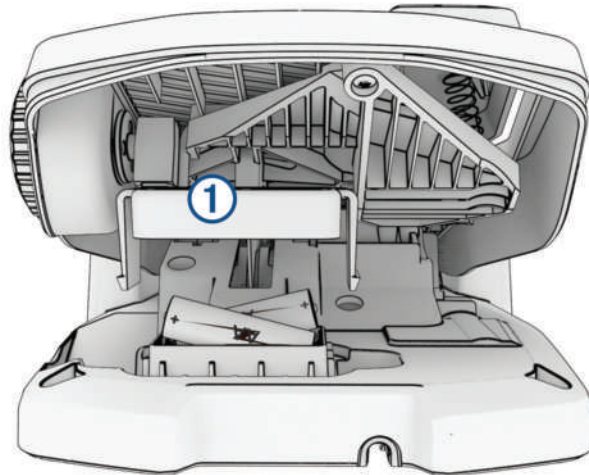

The foot pedal can operate using two AA alkaline, NiMH, or lithium batteries (not included). Use lithium batteries for best results.

- 1 Lift up the front of the foot pedal as far as possible.
- 2 Pinch the sides of the battery cover ①, and pull up to remove it.



- 3 Insert two AA batteries, observing polarity.
- 4 Place the battery cover over the batteries, and push down until both sides snap into place.

Pairing the Foot Pedal

- 1 Turn on the trolling motor.
- 2 On the trolling motor display panel, press  three times to enter pairing mode.
 on the trolling motor display panel illuminates blue as it searches for a connection.
- 3 Bring the foot pedal within 1 m (3 ft.) of the display panel on the trolling motor.
- 4 Connect the foot pedal to power using the power cable, or insert batteries to turn it on.
- 5 Within 30 seconds of turning on the foot pedal, hold  until the status LED on the foot pedal illuminates blue.
- 6 Release .

The status LED on the foot pedal illuminates blue as it searches for a connection, then turns off when it pairs successfully with the trolling motor.

 on the trolling motor display panel changes to green when the connection is successful.

Status Indicator

The LED on the foot pedal indicates the foot pedal status.

Illuminates green	The foot pedal is powering on.
Illuminates and flashes blue	The foot pedal is pairing. The LED turns off when it connects to the trolling motor or the pairing process times out without connecting.
Flashes green when pushing a button	The foot pedal is connected to the trolling motor and sending a command for the button being pushed.
Flashes red when pushing a button	The foot pedal is not connected to the trolling motor.
Off	The LED turns off when the pedal is connected to the trolling motor and not sending commands. This prolongs battery life.

Disabling the Autopilot Buttons on the Foot Pedal

Before you can disable or re-enable the autopilot buttons on the foot pedal, you must make sure the foot pedal has power.

You can individually disable the heading hold button (⬆️) and the anchor lock button (⚓) on the foot pedal to avoid accidentally engaging them.

Quickly press the button six times to disable it.

The status LED turns red for 1 second to indicate that the button is disabled.

TIP: To enable the button again, quickly press it six times. The status LED turns green for one second to indicate that the button is enabled.

Maintenance Needs and Schedule

NOTICE

After using the motor in salt water or brackish water, you must rinse off the entire motor with fresh water, and apply a water-based silicone spray using a soft cloth. You must avoid spraying jets of water at the shaft cap, to prevent water ingress that could lead to product damage.

To maintain your warranty, you must perform routine maintenance tasks to prepare your motor for the season. If you transport the motor in dry and dusty environments such as gravel or dirt roads, you should repeat these tasks during the season as needed.

For service instructions and information on replacement parts, see the *Field Service Manual* on garmin.com/manuals/force_kraken_trolling_motor.

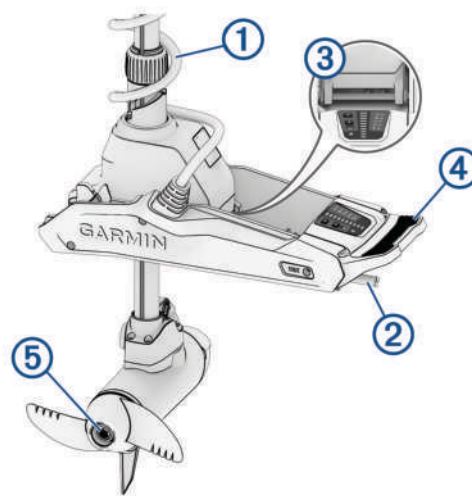

- Examine the coil cable ① for wear, and replace it as necessary.
- Check and clean the power cables ②.
- Lubricate the hinge ③ with marine grade grease (*Lubricating the Hinge*, page 27).
- Clean and lubricate the stow and deploy latch pedal ④ (*Cleaning and Lubricating the Locking Mechanism*, page 28) and latch bar.
- Clean or replace the anodes ⑤ in the propeller drive motor (*Servicing the Anodes*, page 28).
- Remove entangled fishing line and other obstructions from the propeller.

Lubricating the Hinge

The hinge allows the motor to transition smoothly from the stowed to deployed position and back again. You should lubricate the hinge as needed.

- 1 Ensure the motor is in the deployed position.
- 2 Locate the two hinge points ①.

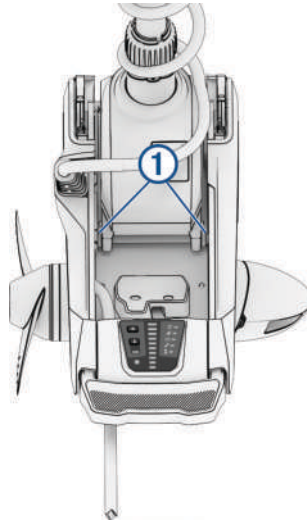

- 3 Apply a non-stick, dry-film lubricant to each hinge point, in the space between the moving parts ②, and allow it to dry according to the instructions provided with the product.

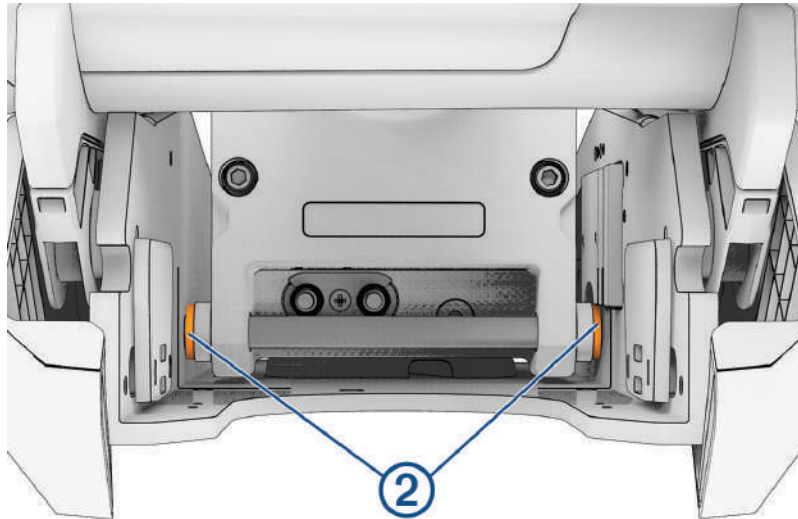

- 4 Move the motor from the stowed to the deployed position and back a number of times to distribute the lubricant.
- 5 If necessary, apply additional lubricant and repeat the previous step.

Cleaning and Lubricating the Locking Mechanism

NOTE: This procedure is best performed with the motor in the stowed position.

- 1 Place the motor in the stowed position so you can access the locking mechanisms ①.

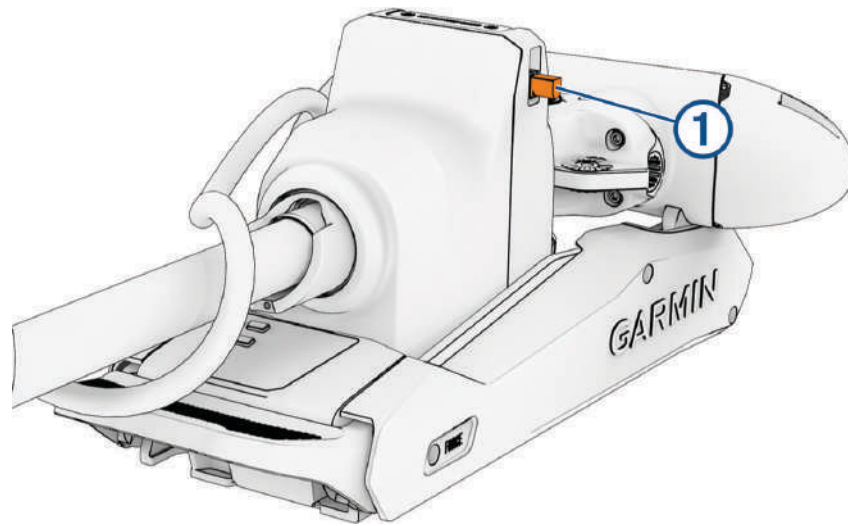

- 2 Clean any debris, dirt, and build up from all of the locking mechanism channels.
- 3 Apply a synthetic or marine grade, general-purpose grease to the locking mechanism and the channels.
- 4 Manually move the latch a number of times to move the mechanism in the channels and distribute the grease.
- 5 If necessary, apply additional grease and repeat the previous step.
- 6 Clean any debris, dirt, and build up from the latch receiver ②.

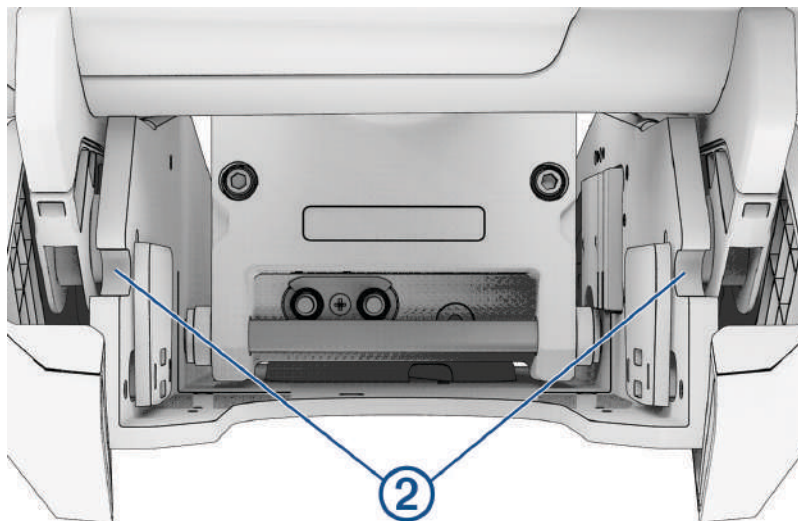

- 7 Apply a synthetic or marine grade, general-purpose grease to the latch receiver and both ramped surfaces and slots on the mount base so the locking mechanism slides smoothly into the receiver.

Servicing the Anodes

⚠ WARNING

Always disconnect the motor from the battery before handling or working with the propeller, propeller drive motor, electrical connections, or electronics enclosures to avoid serious injury or death.

The sacrificial anodes protect the motor components from corrosion. Each season they must be examined and cleaned or replaced if necessary. You can purchase replacement anodes from your Garmin dealer or you can go to garmin.com.

Servicing the Propeller Anode

- 1 Using a $\frac{9}{16}$ in (15 mm) socket, loosen the nut on the end of the propeller.
- 2 Remove the propeller and set aside the nut, the lock washer and the flat washer.
- 3 Remove and examine the anode ①.

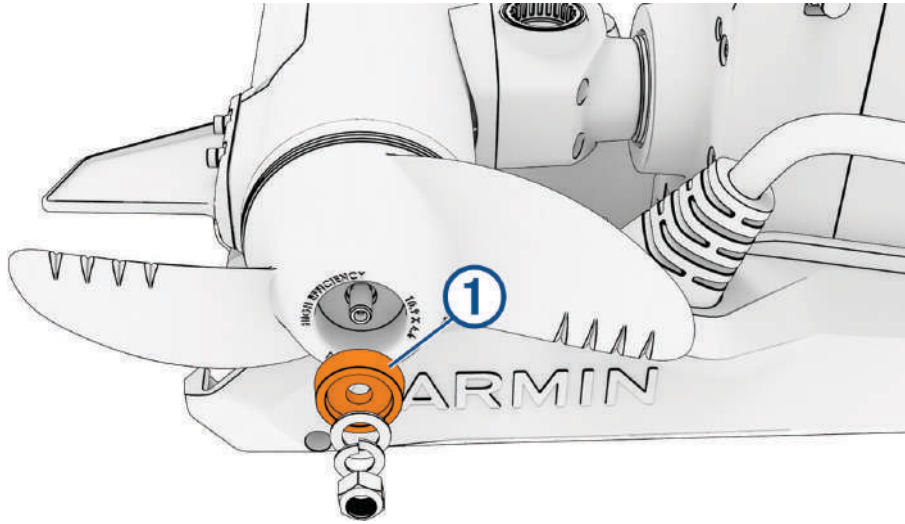

- 4 Select an option:
 - If the anode is half of the original size or larger, clean the anode using a wire brush or sandpaper.

NOTICE

Remove the anode from the motor before cleaning it with a wire brush or sandpaper. Cleaning the anode while installed on the motor could damage the motor, accelerate corrosion, and shorten the life of the motor.

- If the anode is smaller than half of the original size, discard the anode and purchase a replacement.
- 5 Place the cleaned or new anode back on the propeller drive shaft, followed by the flat washer, the lock washer and the nut.
 - 6 Using a $\frac{9}{16}$ in (15 mm) socket, tighten the nut to 16.27 N-m (12 lbf-ft) to secure the propeller.

Servicing the Nose Cone Anode

NOTE: Trolling motors built after 2024 use two screws to secure the anode to the propeller drive motor housing. If your replacement anode has two holes, but your propeller drive motor only has one hole, you can install the new anode using only one screw, and discard the other screw.

- 1 Using a 4 mm hex bit or wrench, remove the four screws securing the skeg on the bottom of the motor.
- 2 Using a 3 mm hex bit or wrench, remove the screw that secures the transducer and nose cone to the bottom of the motor .
- 3 Using a 4 mm hex bit or wrench, remove the screws to disconnect the nose cone from the front of the motor.
- 4 Using a 3 mm hex bit or wrench, uninstall the anode ① on the front of the motor.

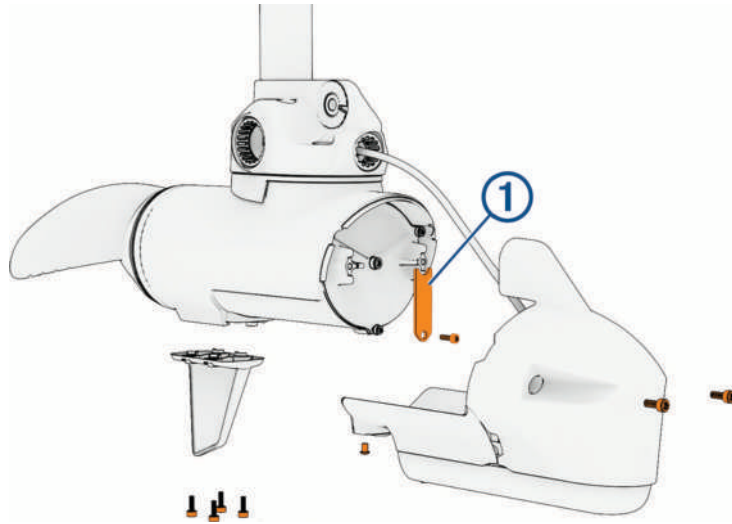

- 5 Examine the anode, and complete an action:
 - If the anode is half of the original size or larger, clean the anode using a wire brush or sandpaper.
 - If the anode is smaller than half of the original size, discard the anode and purchase a replacement.
- 6 Secure the new or cleaned anode to the propeller drive motor using one or two screws.

NOTE: If your propeller drive motor has two mounting points for the anode, you should always use two screws to secure the anode.
- 7 Reinstall the nose cone, using two screws to secure it to the front of the propeller drive motor.
- 8 Reinstall the screw that secures the transducer and nose cone to the bottom of the propeller drive motor.
- 9 Reinstall the skeg on the bottom of the propeller drive motor.

Specifications

Trolling Motor

Weight (motor, mount, and cables)	48 in. white model: 22.6 kg (50 lb.) 48 in. black model: 23.2 kg (51 lb.) 63 in. white model: 24 kg (53 lb.) 63 in. black model: 24.5 kg (54 lb.) 75 in. white model: 24.5 kg (54 lb.) 75 in. black model: 25.4 kg (56 lb.) 90 in. white model: 25 kg (55 lb.) 90 in. black model: 25 kg (55 lb.) 110 in. white model: 26.2 kg (58 lb.) 110 in. black model: 26.2 kg (58 lb.)
Weight (stabilizer)	0.66 kg (1.45 lb.)
Operating temperature	From -5° to 40°C (from 23° to 104°F)
Storage temperature	From -40° to 85°C (-40° to 185°F)
Material	Mount and motor housing: aluminum Shaft cap, display panel, and side panels: plastic Motor shaft: fiberglass
Water rating	Shaft cap: IEC 60529 IPX5 ³ Steering motor housing: IEC 60529 IPX7 ⁴ Display panel housing: IEC 60529 IPX7 ⁴ Propeller drive motor housing: IEC 60529 IPX8 ⁵
Compass safe distance	61 cm (2 ft.)
Power cable length	1.2 m (4 ft.)
Input voltage	From 20 to 45 Vdc
Input amperage	60 A continuous
Breaker (not included)	42 VDC or greater, suitable for 60 A continuous NOTE: You can protect the system by using a larger circuit breaker, not to exceed 90 A, if you are operating under high temperatures or if you are sharing the circuit with other devices. You should verify that your boat wiring meets marine wiring standards using a larger breaker before changing it.
Main power usage at 36 Vdc 60 A	Off: 72 mW Full power: 2160 W
Radio frequency	2.4 GHz @ 17.4 dBm Max

³ Withstands projected water exposure from any direction (such as rain).

⁴ Withstands incidental exposure of water up to 1 m for up to 30 min.

⁵ Withstands continuous immersion in water up to 3 m deep.

Stowed Dimensions

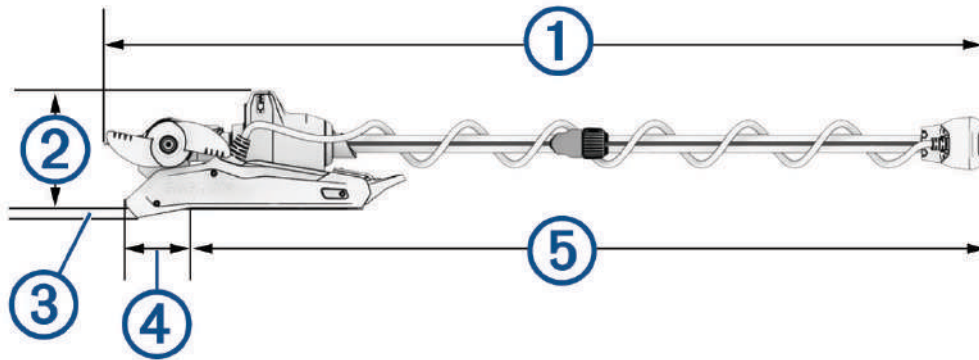

Item	48 in. Model	63 in. Model	75 in. Model	90 in. Model	110 in. Model
①	156 cm (61 ⁷ / ₁₆ in.)	194.1 cm (76 ⁷ / ₁₆ in.)	224.8 cm (88 ¹ / ₂ in.)	262.68 cm (103 ³ / ₈ in.)	313.48 cm (123 ³ / ₈ in.)
②	26.2 cm (10 ⁵ / ₁₆ in.)	26.2 cm (10 ⁵ / ₁₆ in.)	26.2 cm (10 ⁵ / ₁₆ in.)	26.2 cm (10 ⁵ / ₁₆ in.)	26.2 cm (10 ⁵ / ₁₆ in.)
③	1.7 cm (¹¹ / ₁₆ in.)	1.7 cm (¹¹ / ₁₆ in.)	1.7 cm (¹¹ / ₁₆ in.)	1.7 cm (¹¹ / ₁₆ in.)	1.7 cm (¹¹ / ₁₆ in.)
④	20.7 cm (8 ¹ / ₈ in.)	20.7 cm (8 ¹ / ₈ in.)	20.7 cm (8 ¹ / ₈ in.)	20.7 cm (8 ¹ / ₈ in.)	20.7 cm (8 ¹ / ₈ in.)
⑤	130.2 cm (51 ⁵ / ₁₆ in.)	168.3 cm (66 ¹ / ₄ in.)	206.4 cm (81 ¹ / ₄ in.)	236.88 cm (93 ¹ / ₄ in.)	287.68 cm (113 ¹ / ₄ in.)

Deployed Dimensions

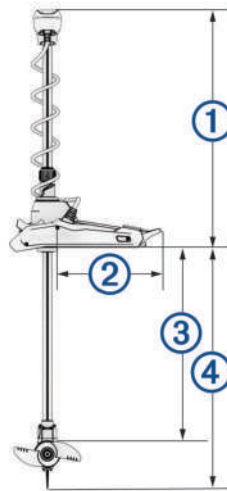

Item	48 in. Model	63 in. Model	75 in. Model	90 in. Model	110 in. Model
①	48.6 cm (19 1/8 in.) ⁶	48.6 cm (19 1/8 in.) ⁶	48.6 cm (19 1/8 in.) ⁶	48.6 cm (19 1/8 in.) ⁶	48.6 cm (19 1/8 in.) ⁶
②	46 cm (18 1/8 in.)	46 cm (18 1/8 in.)	46 cm (18 1/8 in.)	46 cm (18 1/8 in.)	46 cm (18 1/8 in.)
③	87.95 cm (34 5/8 in.)	126 cm (49 5/8 in.)	156.5 cm (61 5/8 in.)	194.6 cm (76 5/8 in.)	245.4 cm (96 5/8 in.)
④	107.32 cm (42 1/4 in.) ⁶	145 cm (57 1/4 in.) ⁶	175.9 cm (69 1/8 in.) ⁶	213.7 cm (84 1/8 in.) ⁶	264.5 cm (104 1/8 in.) ⁶

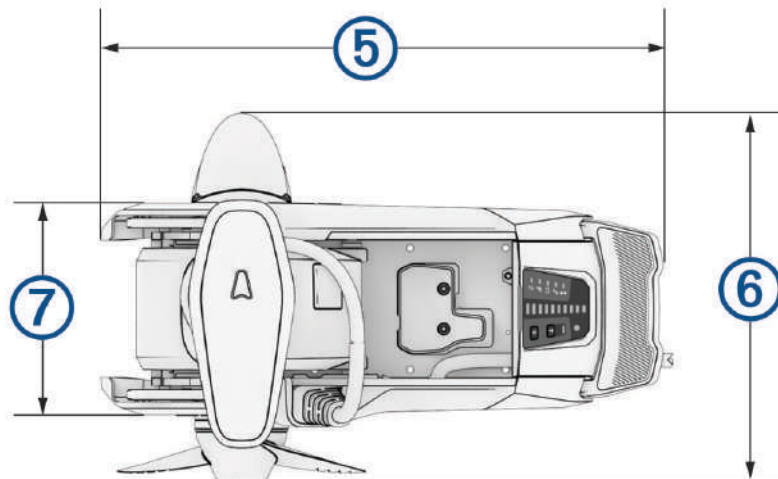

⁶ When deployed at maximum depth.

Item	All Models
⑤	61.2 cm (24 1/8 in.)
⑥	With transducer: 42.7 cm (16 13/16 in.) Without transducer: 41.2 cm (16 1/4 in.)
⑦	24.6 cm (9 11/16 in.)

Motor Thrust and Current-Draw Information

You can refer to these tables to understand the relationship between the throttle level, output power, and current consumption of the motor. These values are gathered based on the ISO13342 test setup, using the Garmin high efficiency propeller, in relatively calm water, with the motor deployed deeply enough not to ventilate, and with tolerances of ± 22 N (5 lbf) and ± 5 A. Voltage levels have been measured at the trolling motor power cable terminals.

Propeller Speed Setting	25.6 Vdc Power Source			38.4 Vdc Power Source		
	Thrust (lbs.)	Thrust (N)	Current (A)	Thrust (lbs.)	Thrust (N)	Current (A)
20	90.0	400.3	58.9	114.7	510.1	55.9
19	81.7	363.3	50.0	86.7	385.5	36.6
18	74.3	330.7	43.1	79.7	354.4	31.7
17	68.0	302.5	37.5	72.0	320.3	27.2
16	61.7	274.3	32.0	65.0	289.1	23.1
15	55.3	246.1	27.3	59.3	263.9	19.7
14	50.0	222.4	23.2	53.0	235.8	16.6
13	44.0	195.7	19.4	47.0	209.1	13.8
12	39.0	173.5	16.1	40.7	180.9	11.3
11	34.0	151.2	13.3	36.0	160.1	9.3
10	29.7	132.0	10.8	30.7	136.4	7.5
9	26.0	115.7	8.7	26.0	115.7	5.8
8	22.0	97.9	6.9	22.7	100.8	4.6
7	18.0	80.1	5.3	18.0	80.1	3.5
6	15.0	66.7	4.1	15.0	66.7	2.6
5	12.0	53.4	3.1	11.7	51.9	1.9
4	9.7	43.0	2.2	9.0	40.0	1.4
3	7.0	31.1	1.5	7.0	31.1	0.9
2	5.0	22.2	1.0	5.0	22.2	0.6
1	3.7	16.3	0.6	3.0	13.3	0.3
-1	1.0	4.4	0.2	1.0	4.4	0.2
-2	2.0	8.9	0.8	2.3	10.4	0.5
-3	5.0	22.2	1.9	5.0	22.2	1.4
-4	8.0	35.6	4.0	9.0	40.0	2.8
-5	9.3	41.5	4.9	13.3	59.3	5.2
-6	11.0	48.9	5.8	15.3	68.2	6.4
-7	12.7	56.3	7.0	17.3	77.1	7.6
-8	14.7	65.2	8.5	19.3	86.0	9.0
-9	15.7	69.7	9.9	21.0	93.4	10.4
-10	17.3	77.1	11.6	24.0	106.8	12.4
-11	19.3	86.0	13.8	26.3	117.1	14.7

Propeller Speed Setting	25.6 Vdc Power Source			38.4 Vdc Power Source		
	Thrust (lbs.)	Thrust (N)	Current (A)	Thrust (lbs.)	Thrust (N)	Current (A)
-12	21.7	96.4	16.3	29.0	129.0	17.4
-13	23.7	105.3	18.8	32.0	142.3	20.0
-14	26.0	115.7	21.8	35.3	157.2	23.6
-15	28.0	124.6	25.2	39.0	173.5	27.4
-16	31.0	137.9	29.3	44.0	195.7	32.1
-17	34.3	152.7	34.1	48.0	213.5	37.3
-18	37.3	166.1	39.4	52.3	232.8	42.9
-19	41.0	182.4	45.7	51.7	229.8	50.1
-20	48.0	213.5	57.4	62.3	277.3	55.1

NOTE: Negative propeller speed values refer to the propeller running in reverse ([Reverse Thrust, page 16](#)).

Remote Control

Dimensions (W×H×D)	152 x 52 x 32 mm (6 x 2 x 1 ¹ / ₄ in.)
Weight	109 g (3.8 oz.) without batteries
Material	Glass-filled nylon
Display type	Sunlight-visible, transfective memory-in-pixel (MIP)
Display resolution	R240 x 240 pixels
Display size (diameter)	30.2 mm (1 ³ / ₁₆ in.)
Operating temperature	From -15° to 55°C (5° to 131°F)
Storage temperature	From -40° to 85°C (-40° to 185°F)
Battery type	2 AA (not included)
Battery life	240 hr., typical use
Radio frequency	2.4 GHz @ 10.0 dBm nominal
Water rating	IEC 60529 IPX7 ⁷
Compass-safe distance	15 cm (6 in.)

⁷ Withstands incidental exposure of water up to 1 m for up to 30 min.

Foot Pedal

Dimensions (L×W×H)	303 × 221 × 110 mm (11 ¹⁵ / ₁₆ × 8 ¹¹ / ₁₆ × 4 ⁵ / ₁₆ in.
Weight	1.8 kg (4 lb)
Operating temperature	From -15° to 55°C (5° to 131°F)
Storage temperature	From -40° to 85°C (-40° to 185°F)
Water rating	IEC 60529 IPX7
Material	Plastic
Input voltage	From 10 to 45 Vdc
Rated input voltage	12/24/36 Vdc
Typical input current	< 1 mA @ 12 Vdc
Max input current	10 mA @ 12 Vdc
Fuse (on the power cable)	2 A mini-blade type
Power cable length	2 m (6.6 ft.)
Battery type	Two AA batteries (Alkaline, NiMH, or lithium. Not included.)
Battery life	At least 1 year
Radio frequency	2.4 GHz @ 0.72 dBm nominal
Compass-safe distance	60 cm (2 ft.)

Network Interfaces and Services

The equipment, when connected using Wi-Fi, may use these network interfaces and services. These interfaces and services are enabled by default, cannot be disabled, and are required for proper equipment operation.

- Garmin proprietary services
- DHCP
- HTTP
- mDNS
- Telnet

NOTE: When you connect the equipment to the network, private information is synchronized with the newly-added equipment.

