

BTR Series

REV 001C

CE

UK
CA

January, 2023

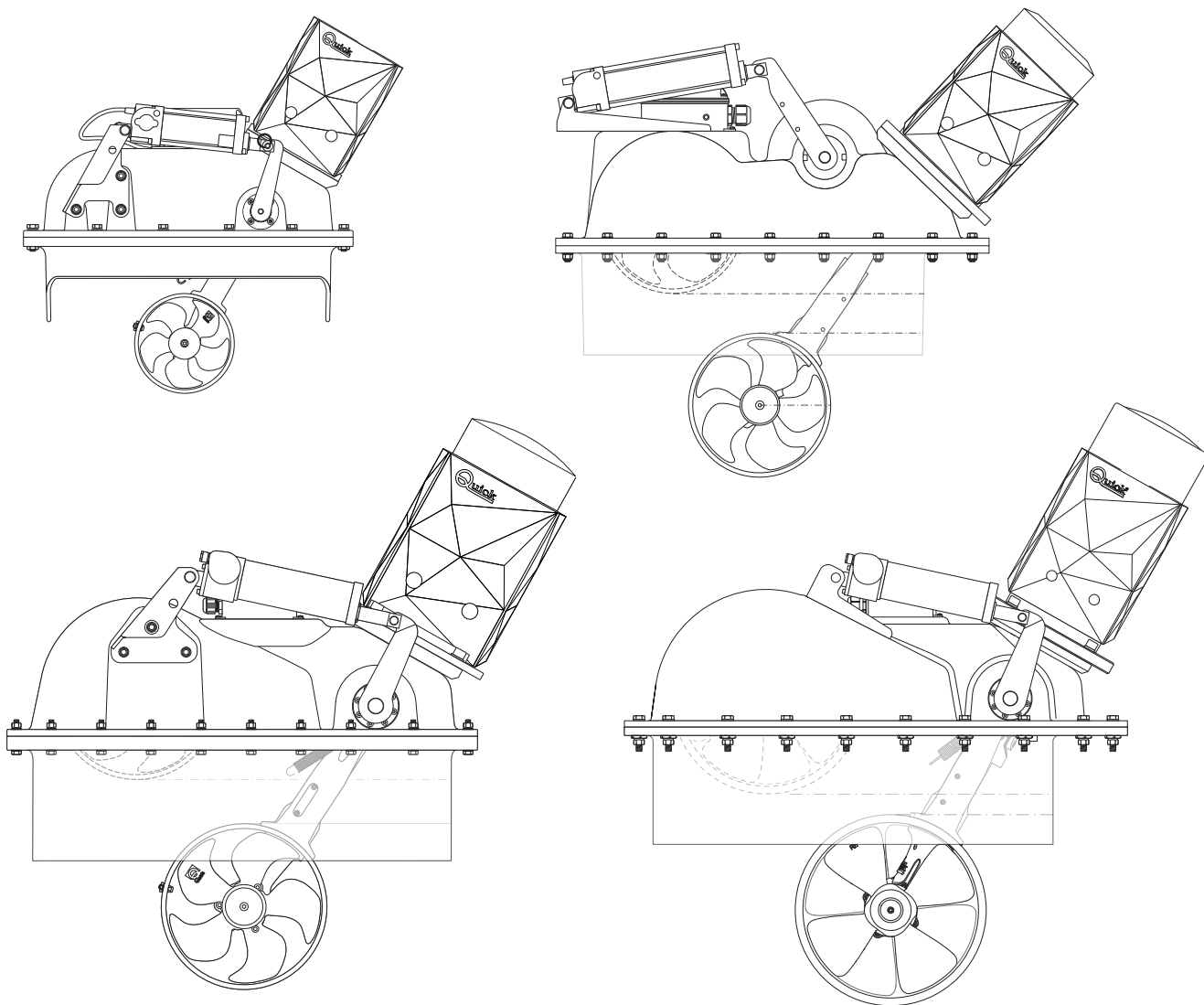
RETRACTABLE THRUSTERS

BTR 140 30 - 140 40

BTR 185 65 - 185 85 - 185 105

BTR 250 120 - 250 140 - 250 240

BTR 300 250 - 300 270 - 300 300



*EN - INSTALLATION AND USER'S MANUAL

*Other languages available by scanning the QR code on the back of this manual or on the label on the product.

Quick[®]
Nautical Equipment

IT *Altre lingue disponibili scansionando il codice QR presente sul retro del seguente manuale o sull'etichetta alloggiata sul prodotto.

ES *Otros idiomas disponibles escaneando el código QR en la parte posterior de este manual o en la etiqueta del producto.

FR *Autres langues disponibles en scannant le code QR au dos de ce manuel ou sur l'étiquette du produit.

DE *Andere Sprachen sind durch Scannen des QR-Codes auf der Rückseite dieser Betriebsanleitung oder auf dem Aufkleber am Produkt verfügbar.

PT *Outros idiomas disponíveis, digitalizando o código QR no verso deste manual ou no rótulo do produto.

1 - Information about the product	5
1.0 - Technical Data	5
2 - Supply and equipment	6
2.0 - Standard supply and material included in the package	6
2.1 - Tools required for installation	6
2.2 - Recommended Quick® accessories not included	6
3 - Introduction	6
3.0 - Important notes	6
3.1 - Precautions	7
3.2 - Precautions for the installer	7
3.3 - Installation requirements	7
4 - Installation	8
4.0 - Thrusters position	8
4.1 - Counter flange installation	9
4.2 - Construction and installation of the closing hatch	11
4.3 - Retractable thruster installation	13
4.4 - Motor installation	14
4.5 - Check and mechanical adjustment of the system	14
4.6 - Installing the cable in the hatch	14
4.7 - Adjustment procedure	15
4.8 - Actuator adjustment	16
4.9 - Installing spring end-of-stroke cables	16
5 - Wiring diagram	17
5.0 - BTR basic system	17
5.1 - RTC R1 board	18
6 - Operation	19
6.0 - Dip-Switch for option selection	19
6.1 - Actuator current rotary selector	19
7 - Signalling	20
7.0 - Light signals	20
8 - Important warnings	21
8.0 - Important cautions	21
9 - Use	21
9.0 - Retractable thruster use	21
9.1 - Manual closing of the thruster in case of emergency	22
10 - Maintenance	22
11 - Product disposal	22
12 - List of components	23
12.0 - BTR 140	24
12.1 - BTR 185	25
12.2 - BTR 250	26
12.3 - BTR 300	27
13 - Spare parts	28
14 - Dimensions	29



READ THIS INSTRUCTION MANUAL CAREFULLY BEFORE USING THE PRODUCT. IF IN DOUBT, CONTACT YOUR QUICK® DEALER.



QUICK® RESERVES THE RIGHT TO MODIFY THE TECHNICAL CHARACTERISTICS OF THE EQUIPMENT AND THE CONTENTS OF THIS MANUAL WITHOUT PRIOR NOTICE. IN CASE OF DISCORDANCE OR ERRORS IN TRANSLATION BETWEEN THE TRANSLATED VERSION AND THE ORIGINAL TEXT IN THE ITALIAN LANGUAGE, REFERENCE WILL BE MADE TO THE ITALIAN TEXT.

1.0 - Technical Data

MODELS	BTR 140-30	BTR 140-40
No. of Propellers	Single	
Tunnel Ø	140mm (5" 33/64)	
Motor power	1.5 kW	2.2 kW
Voltage	12 V	12 V
Fuse	150A CNL DIN	225A CNL DIN
Thrust	30 kgf (66 lb)	40 Kgf (88.2 lb)
Weight	26.4 kg (58.2 lb)	27.3 kg (60.2 lb)
Recommended cable cross-section (*) (**)	L<5m	35mm ² (AWG 2)
	5.1 < L < 10m	50mm ² (AWG 1)
	10.1 < L < 20m	70mm ² (AWG 2/0)

MODELS	BTR 185-65		BTR 185-85		BTR 185-105	
No. of Propellers	2 counter rotating (technopolymer)					
Tunnel Ø	185mm (7" 9/32) in					
Motor power	3.3 kW		4.3 kW			
Voltage	12 V	24 V	12 V	24 V	12 V	24 V
Fuse	275 A CNL DIN	175 A CNL DIN	400 A CNL DIN	275 A CNL DIN	400 A CNL DIN	275 A CNL DIN
Thrust	65 kgf (143.3 lb)		85 kgf (187.4 lb)		105 kgf (231.5 lb)	
Weight	37.6 kg (82.9 lb)	37.8 kg (83.3 lb)	37.9 kg (83.5 lb)	40.5 Kg (89.3 lb)	46.4 kg (102.3 lb)	44 kg (97.0 lb)
Recommended cable cross-section (*) (**)	L<5m	70mm ² (AWG 2/0)	50mm ² (AWG 1)	2 x 50mm ² (2 x AWG 1)	70 mm ² (AWG 2/0)	2 x 70mm ² (2 x AWG 2/0)
	5.1 < L < 10m	2 x 50 mm ² (2 x AWG 1)	70mm ² (AWG 2/0)	2 x 70mm ² (2 x AWG 2/0)	2 x 50mm ² (2 x AWG 1)	2 x 95mm ² (2 x AWG 3/0)
	10.1 < L < 20m	2 x 70 mm ² (2 x AWG 2/0)	95mm ² (AWG 3/0)	2 x 95mm ² (2 x AWG 3/0)	2 x 70mm ² (2 x AWG 2/0)	2 x 120mm ² (2 x AWG 4/0)

MODELS	BTR 250-120	BTR 250-140	BTR 250-240	BTR 300-250	BTR 300-270	BTR 300-300
No. of Propellers	2 counter rotating (technopolymer)					
Tunnel Ø	250 mm (9" 27/32) in			300 mm (11" 13/16) in		
Motor power	6.5 kW	8 kW	10 kW	10 kW	12 kW	15 kW
Voltage	24 V					48 V
Fuse	275 A CNL DIN	400 A CNL DIN	400 A CNL DIN	400A CNL DIN	500 A CNL DIN	500 A CNL DIN
Thrust	120 kgf (264 lb)	140 kgf (308 lb)	240 kgf (529 lb)	250 kgf (551 lb)	270 kgf (595 lb)	300 kgf (660 lb)
Weight	82.1 kg (181 lb)		97 kg (213.8 lb)	97 kg (214lb)	106 kg (234 lb)	113 kg (249 lb)
Recommended cable cross-section (*) (**)	L<5m	70mm ² (AWG 2/0)	2 x 50mm ² (2 x AWG 1)	70mm ² (AWG 2/0)	2 x 95mm ² (2 x AWG 3/0)	95mm ² (AWG 3/0)
	5.1 < L < 10m	2 x 50mm ² (2 x AWG 1)	2 x 70mm ² (2 x AWG 2/0)	2 x 50mm ² (2 x AWG 1)	2 x 95mm ² (2 x AWG 3/0)	2 x 70 mm ² (2 x AWG 2/0)
	10.1 < L < 20m	2 x 70mm ² (2 x AWG 2/0)	2 x 95mm ² (2 x AWG 3/0)	2 x 95 mm ² (2 x AWG 3/0)	2 x 120mm ² (2 x AWG 4/0)	2 x 95mm ² (2 x AWG 3/0)

(*) L = positive cable + negative cable

(**) Other solutions are allowed, provided that they are supported by the connecting terminals. Respect minimum area indicated.

2.0 - Standard supply and material included in the package

- Retractable thruster
- O-ring
- Hinge
- Hatch bracket
- Steel wire rope
- Installation and user's manual
- Warranty conditions

2.1 - Tools required for installation

- BTR 140**
- Phillips screwdriver
 - Wire cutters
 - Drill and drill bit Ø 8.5 mm
 - Allen wrench: 2.5 mm
 - Fork wrench: 8 mm and 13 mm
- BTR 185**
- Phillips screwdriver
 - Wire cutters
 - Drill and drill bit Ø 8.5 mm
 - Allen wrench: 2.5 mm
 - Fork wrench: 8 mm and 13 mm
- BTR 250**
- Phillips screwdriver
 - Wire cutters
 - Drill and drill bit Ø 8.5 mm
 - Allen wrench: 2.5 mm and 10 mm
 - Fork wrench: 8 mm, 13 mm and 17 mm
- BTR 300**
- Phillips screwdriver
 - Wire cutters
 - Drill and drill bit Ø 8.5 mm
 - Allen wrench: 2.5 mm and 10 mm
 - Fork wrench: 8 mm, 13 mm and 17 mm

2.2 - Recommended Quick® accessories not included

- TCD thruster controls
- TSC integrated line switch control
- TMS line switch
- PSS parallel battery switch
- TFH Fuse holder

3 - Introduction

BTR Series

BEFORE USING THE PRODUCT, PLEASE READ THIS USER'S MANUAL CAREFULLY. IF IN DOUBT, PLEASE CONSULT YOUR QUICK® DEALER.

3.0 - Important notes

This manual features Warning and/or Caution symbols that are important for safety. Please follow the instructions provided.



Warning symbol indicating dangerous situations.



Caution symbol to prevent direct or indirect damage to the product.

This manual provides boat manufacturers and nautical equipment installers with instructions on how to assemble the specified Quick® product and operate it correctly.



3.1 - Precautions



Quick® thrusters have been designed and constructed only for nautical use.

- Do not use these products for any other type of operation.
- Quick® shall not be held liable for direct or indirect damage caused by improper use of the product.
- The product is not designed to support loads generated in particular atmospheric conditions (storms).
- Operate the product from a position where it is possible to supervise the work area.
- Always deactivate the thruster when not being used.
- For improved safety, we recommend installing at least two controls to operate the product in case one is damaged.
- The installer shall bear full responsibility for any problems caused by defective installation of the tunnel.
- This equipment is not intended for use by people (including children) with reduced physical, sensory or mental capabilities.
- Do not install the electric motor near easily inflammable objects.

3.2 - Precautions for the installer



CARRY OUT THE INSTALLATION IN GOOD LIGHTING CONDITIONS.

It is advisable to wear suitable clothing and personal protective equipment (PPE).

The product is not suitable for installation in potentially explosive environments and/or atmospheres. Installation and subsequent inspection or repair work must only be carried out by qualified personnel.



CARRY OUT INSTALLATION/MAINTENANCE WORK MAKING SURE THAT THE PRODUCT IS DISCONNECTED FROM THE ELECTRICAL SYSTEM.

Quick® accepts no responsibility for inadequate connection of users to the electrical system and inadequate safety of the electrical system.

3.3 - Installation requirements

We recommend you entrust preparation and positioning of the tunnel in the hull to a skilled professional.

These are generic instructions and do not give details of the preparatory operations for installing the thruster, since this is the competence of the boatyard. The installer shall bear full responsibility for any problems caused by defective installation.

Although all the components and mechanical moving parts are of high quality, the correct installation of the driving unit is an essential basis for the safe and effective use of the boat as well as the driving unit itself.

The installation of such a unit is an operation that requires experience as well as technical skills. It is recommended that the installation be carried out by competent personnel and that the manufacturer or naval architects be consulted to fully assess the scope of the work.

The Quick® retractable thruster has two separate movements.

The main movement, relative to the driving unit, is of the tilting type. The hinges on which the movement takes place are designed for assembly high resistance and are located on the plane of the flat flanging that links the pre-assembled structure to the support integral to the hull.

The secondary movement relates to the closing movement of the thru-hull from which the tunnel comes out. This tilting movement is performed around the hinge that has been designed and manufactured for an interference-free opening of the hatch (if installed as instructed).

Electric motor, gearbox, linkages and all other components are supplied by Quick® already assembled on the GRP support structure and do not require adjustments, adaptations or sealing, unless specified in this manual.

The Quick® retractable thruster is sold separately from the counter flange which can be supplied in different materials based on the different type of hulls. Quick® can provide stainless steel, aluminium alloy or GRP supports, which are essential for a fast, sturdy and precise installation.

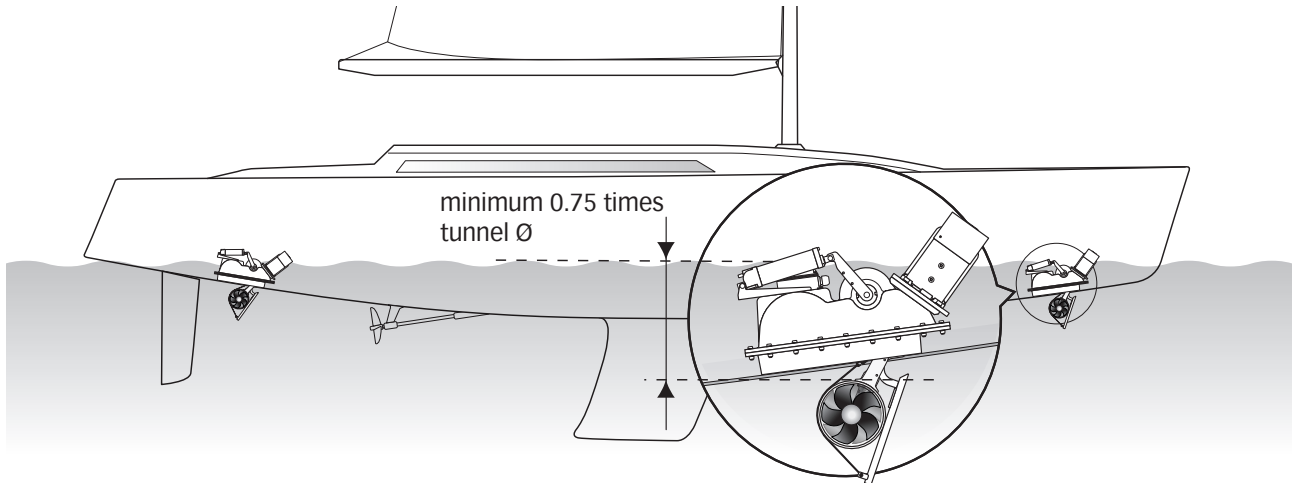
For fibreglass hulls, the support must be laminated in the hull in compliance with current regulations on joints.

The driving unit distributes mechanical stresses to the hull through the counter flange. The strength of the joint will be determined by overlapping laminations, made in a "workmanlike" way.

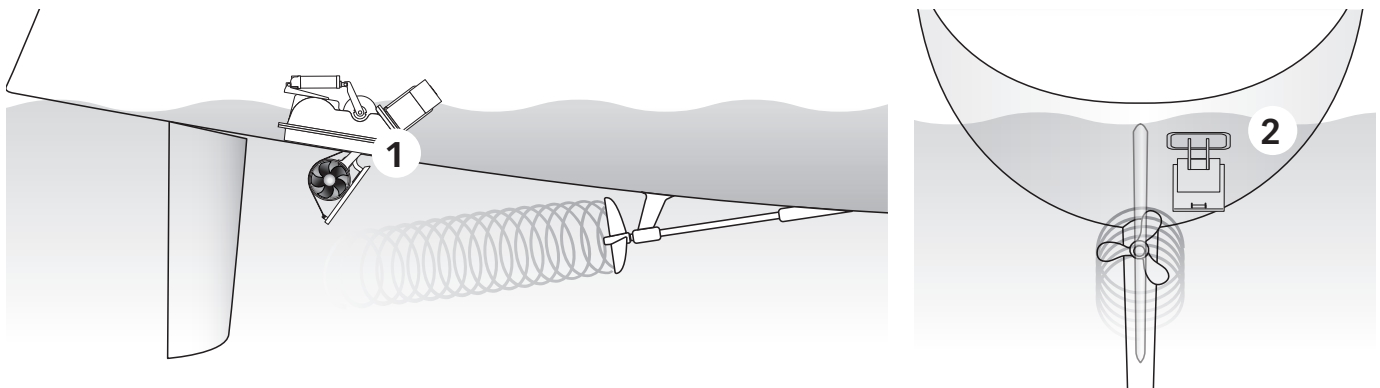
For aluminium alloy hulls or stainless steel hulls, the support needs to be welded to the hull.

If well done, the installation of a box structure such as that of the support can give greater strength to the hull. Refer to the manufacturer, naval architects and/or specialised companies to evaluate additional works such as beams and supporting structures near the position of the retractable driving unit.

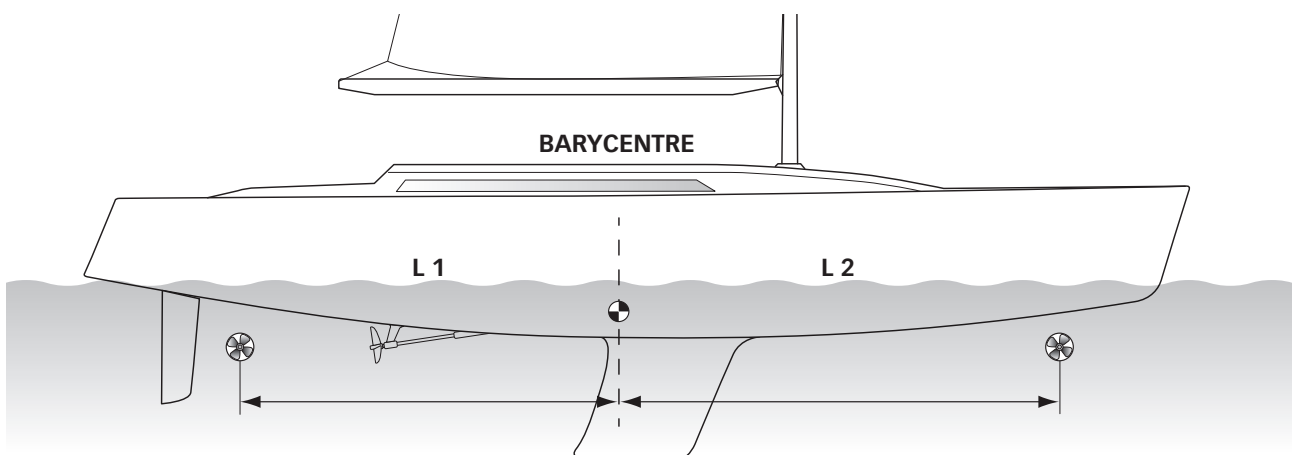
4.0 - Thrusters position



- To avoid cavitation in the thruster, the tunnel must be positioned as low as possible.



- To avoid damage, position the retractable thruster so that the hatch is not affected by the thruster driving cone of the boat (examples 1 and 2), in both directions of travel.



- The longer the lengths L1 and L2, the greater the thrust generated around the barycentre.



4.1 - Counter flange installation

- Protect the seal seat with gummed paper tape to prevent it from getting dirty, until the retractable thruster is installed (Fig. 1A).

FIG. 1A

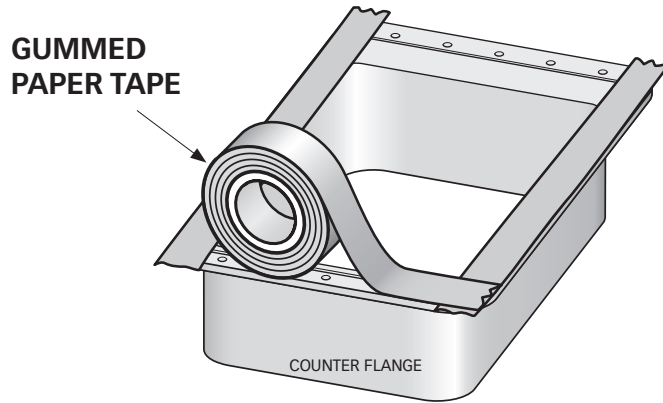
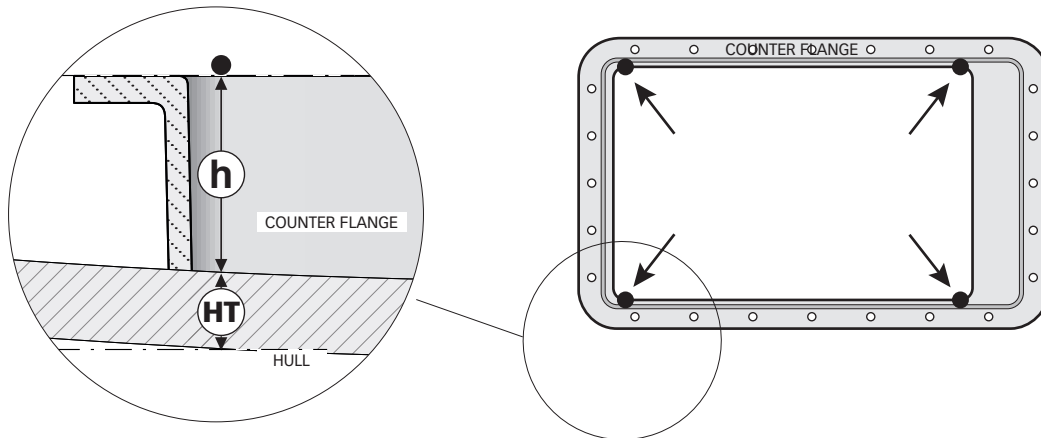
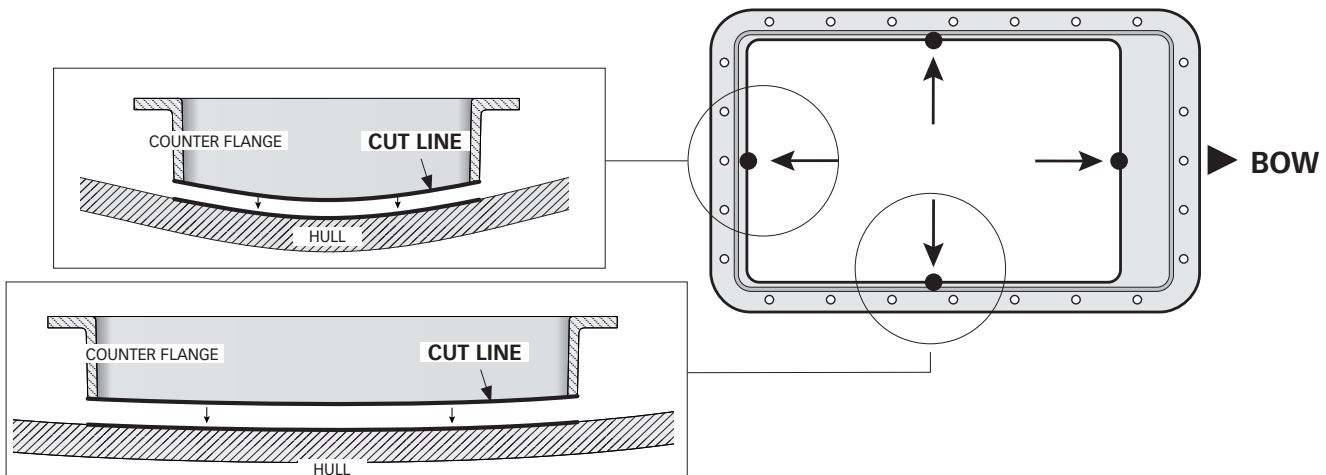


FIG. 1B



- Mark the counter flange with a marker in the four **INDICATED** positions of the long sides (Fig. 1b), refer to the table:

	h	HT
Ø140	37-57mm	30mm
Ø185	60-65mm	35mm
Ø250	65-80mm	40mm
Ø300	110-120mm	40mm



- Shape the central parts of the 4 **indicated** sides of the counter flange by adapting them to the curve of the hull (fig. 1C).

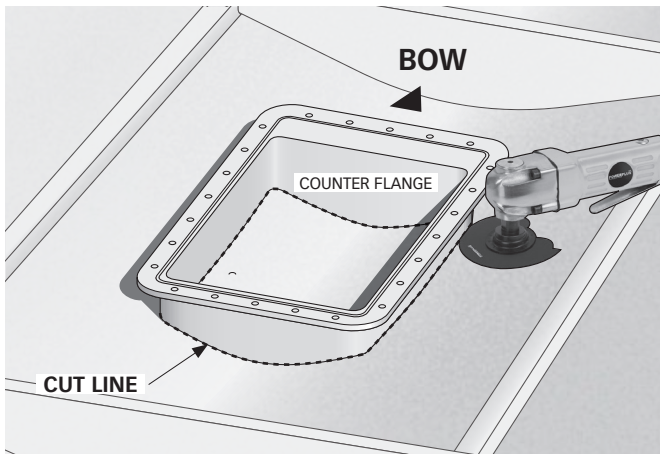


Fig.2

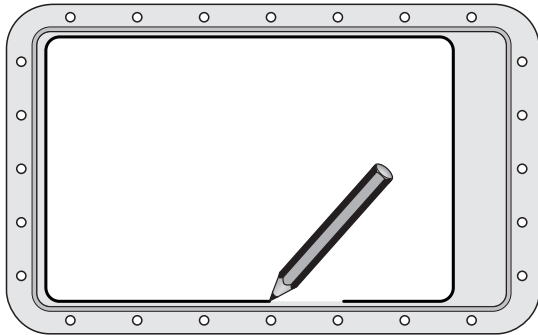


Fig.3

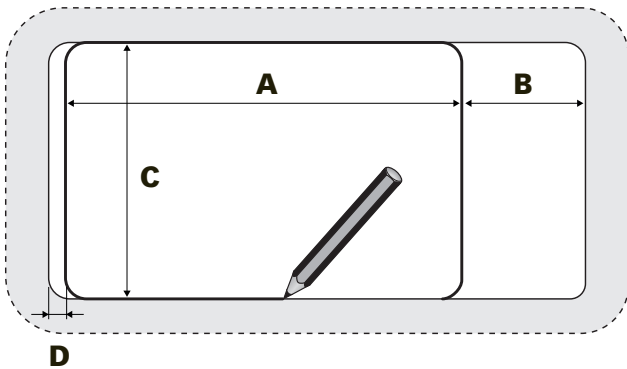
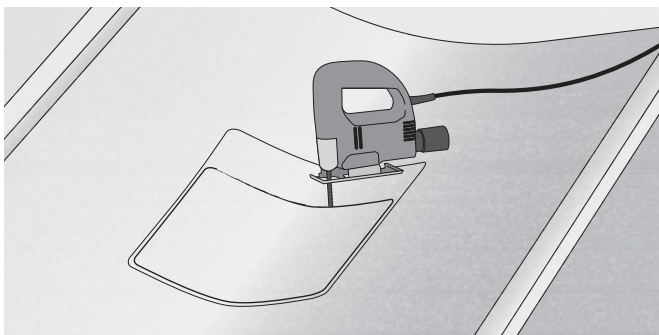


Fig.4



- Place the appropriately cut counter flange and check that the four sides adhere to the hull, if this is not the case, adapt it until it rests and adheres to the hull in the position where it is meant to be fixed.



WARNING: take into account the minimum dimensions for the final placement of the hinge (see fig.13, page 12).

- Mark the inner perimeter of the counter flange on the hull with a marker (fig. 2).

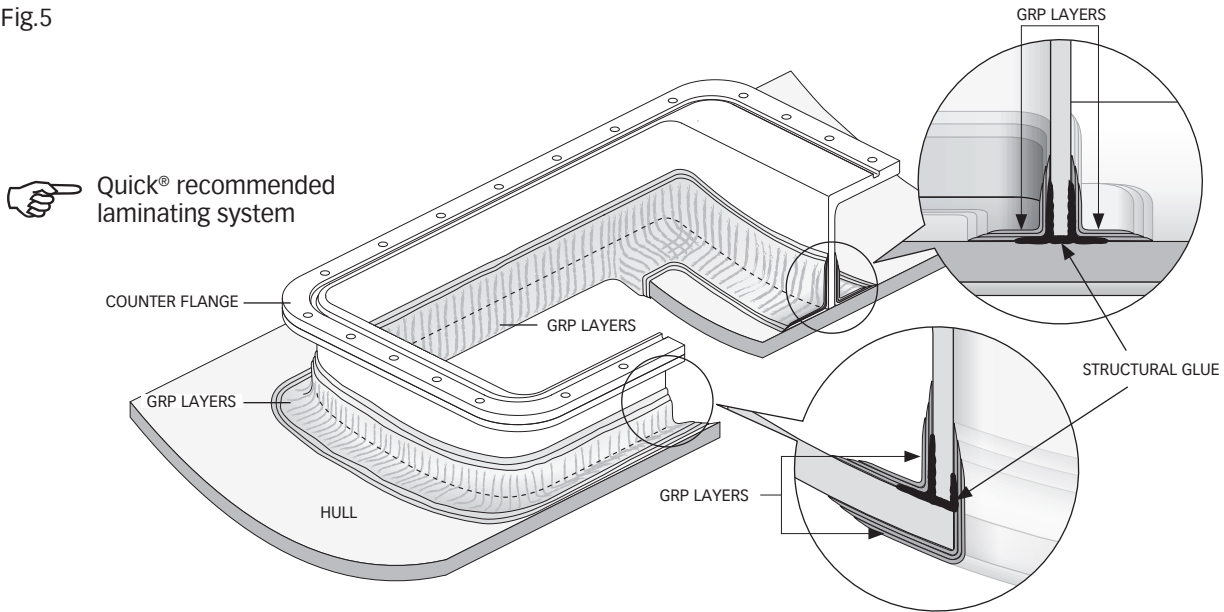
- Remove the counter flange and mark the cutting area: (fig.3)

	Ø140	Ø185	Ø250	Ø300
A	320mm	350mm	480mm	604mm
B	100mm	95mm	150mm	110mm
C	200mm	280mm	310mm	440mm
D	0mm	0mm	20mm	0mm

- Make the hull opening by cutting along the line of the marked cutting area (fig. 4).

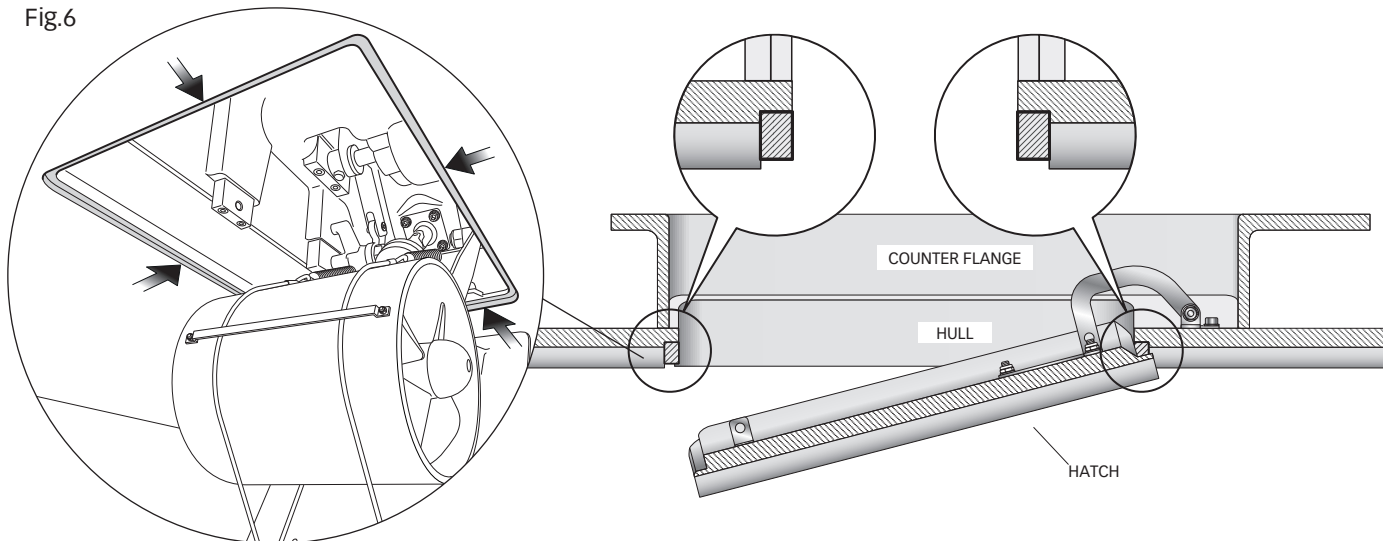


Fig.5



•Align the counter flange with the opening of the hull and **check that the 4 heights indicated in fig.B page 9** are correct. Apply resin to the counter flange or weld it, in the case of aluminium or steel, according to the techniques identified as the most suitable for the type of hull construction (fig. 5).

Fig.6



•On the entire perimeter of the hull opening, make a sturdy stop for closing the hatch (fig. 6).

4.2 - Construction and installation of the closing hatch



WARNING: take special care to avoid interference between the cover and the hull opening. Too precise contacts will cause damage to the entire movement system (fig.7).

Fig.7

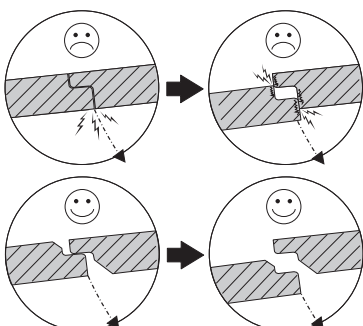


Fig.8

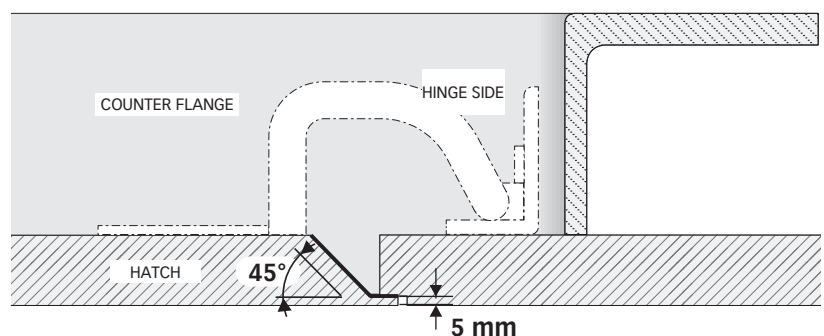


Fig. 9

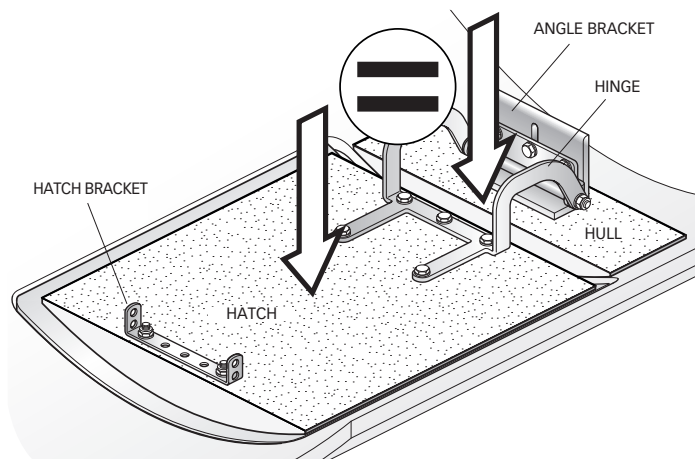
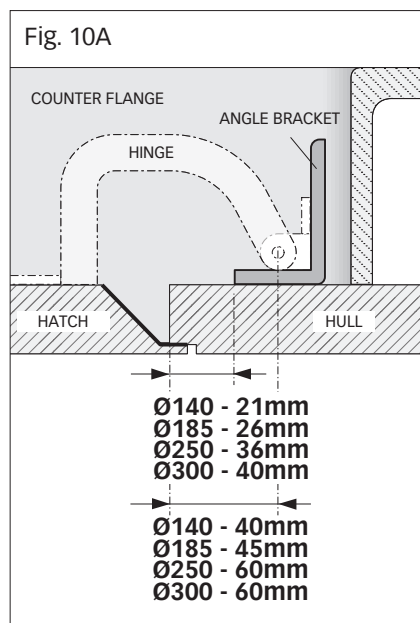


Fig. 10A



- Make the closing hatch maintaining a clearance on all sides from 3 to 5 mm, paying particular attention to the hinge side, making the internal walls inclined at 45° so that they do not interfere with the hull opening (fig.7 and 8).
- To achieve the correct opening of the hinge, the hull and hatch surfaces must be on the same level (fig. 9).
- The thickness of the hull must be max. 35mm (Ø185) 50mm (Ø250) (fig. 8).
- Correctly adjust the angle bracket on the hull (fig. 10A and 10B - ref. A).
- Fix the angle bracket with structural glue (fig. 10B - ref. B1 - B2).
- Choose whether to fix the angle bracket to the hull with 3 M8 screws or by applying resin (fig. 10B - ref. C1 - C2).

Fig. 10B

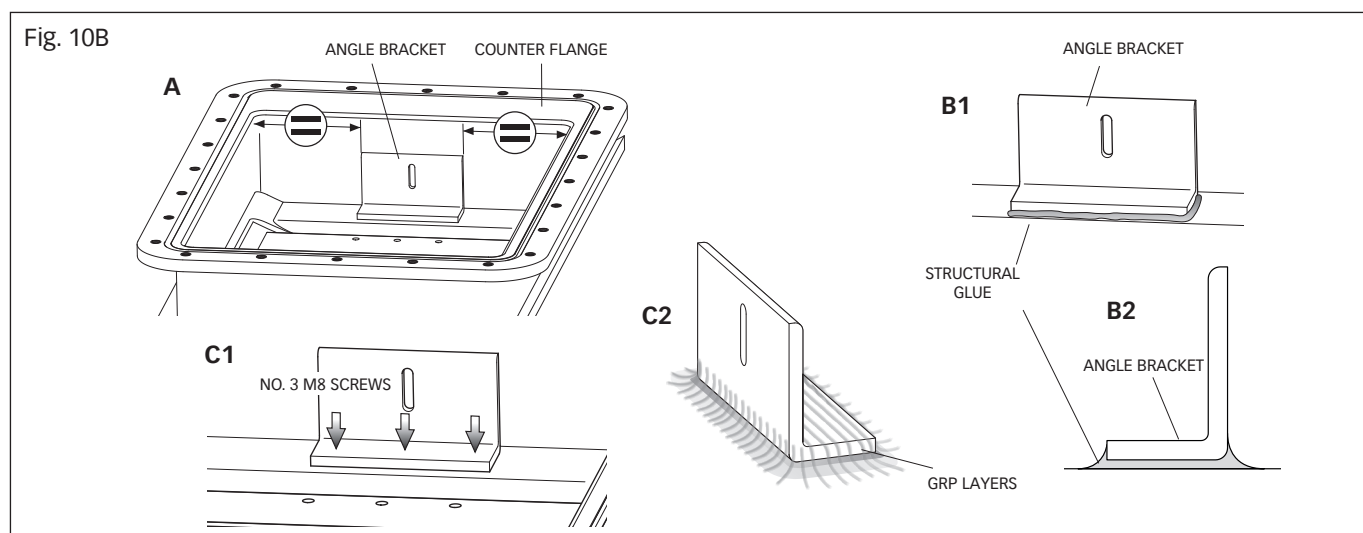
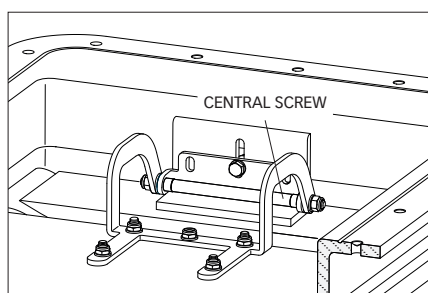


Fig.11



- Temporarily fix the hatch in its seat.
- Screw the hinge onto the angle bracket with the central screw only (fig. 11).
- Place the hinge and hatch bracket in the correct positions.
- Mark all the fixing points (fig. 12), remove the hinge and the hatch bracket and drill with a Ø 8.5mm drill bit.
- Fix the hinge and the hatch bracket in the positions made using stainless steel screws suitable for the application.
- Adjust the central hinge screw (fig. 11) and position it correctly so that the hatch opens unhindered.

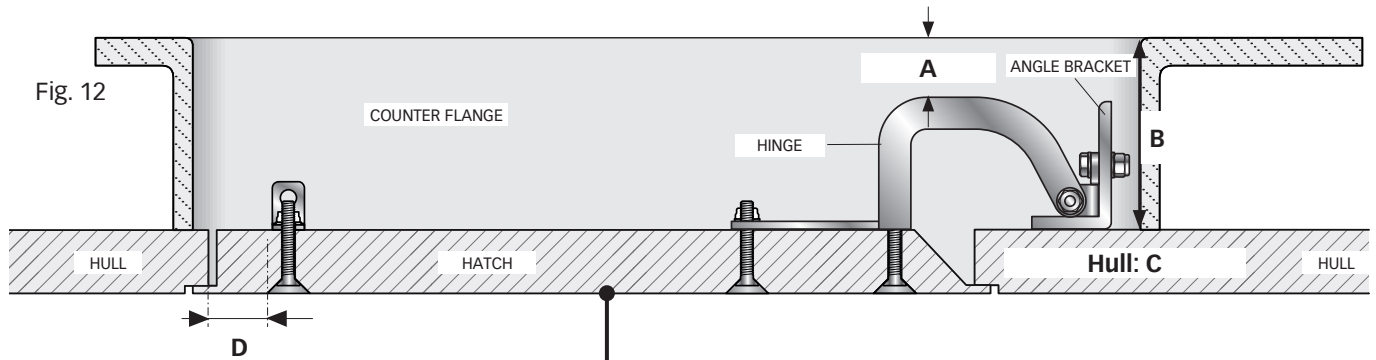
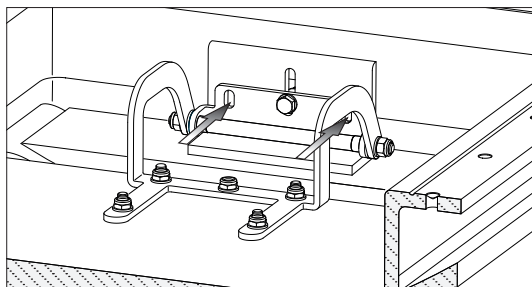


Fig. 13



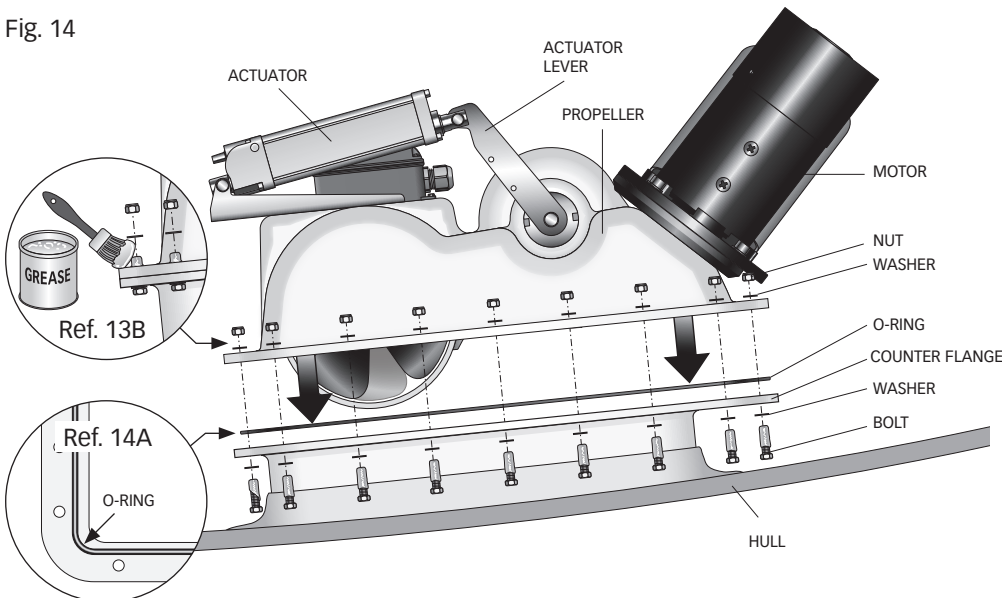
WARNING: for a sturdy fixing of the hinge and bracket, the hatch must not have hollow areas, or non-structural infilling (fig. 12).

	Ø140	Ø185	Ø250	Ø300
A	Min 5mm	Min 5mm	Min 5mm	Min 5mm
B	37-57mm	60-65mm	65-80mm	110-120mm
C	30mm	35mm	40mm	40mm
D	5 mm	15mm	20mm	20mm

- Drill the angle bracket and also secure the other two M8 screws (fig. 13) firmly.

4.3 - Retractable thruster installation

Fig. 14



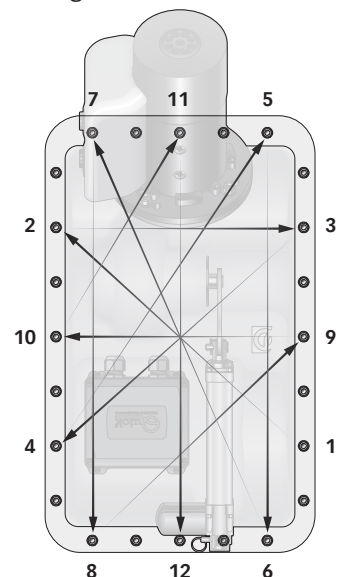
- Remove the previously applied adhesive protectors from the counter flange.
- Verify that the O-ring seat is well cleaned and has not been damaged during installation.
- Position the O-ring correctly on the counter flange (ref. 14A), assemble the retractable thruster (fig. 14), spread marine grease on the bolt threads (ref. 14B) and fix securely with the supplied screws.

The counter flange screws should be tightened to 15Nm, tightening little by little in a cross pattern as in the example in figure 15.



WARNING: after about a week from installation, check the correct tightening of the screws to compensate for any settling of the O-ring.

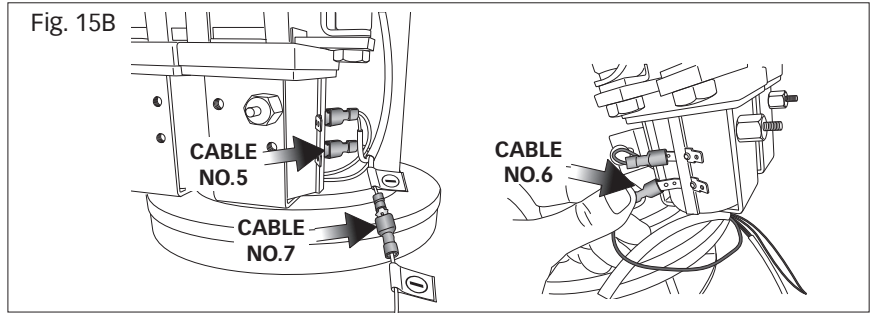
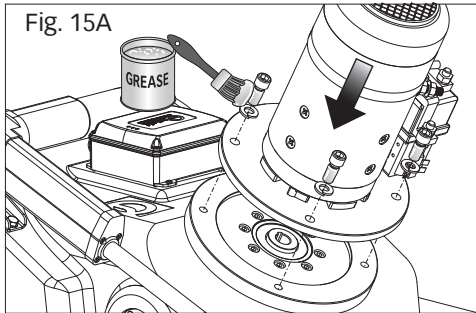
Fig. 15



4.4 - Motor installation

Fig. 15

- Grease the drive shaft and make sure the key is properly positioned.
- Insert the motor and fix it with the suitably greased 4 screws and 4 growers supplied (fig. 15A).
- Connect the fastons respecting the polarities (fig. 15B).



4.5 - Check and mechanical adjustment of the system

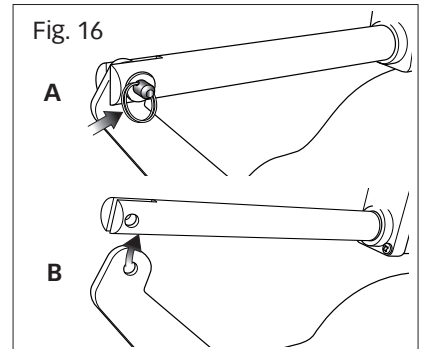
Follow the sequence below to check hatch opening:

Fig. 16

- The retractable thruster should not be powered.
- Remove the ring and the pin (ref. A).
- Release the actuator from the lever (ref. B), make sure the system can be opened and closed smoothly without mechanical hindrance.

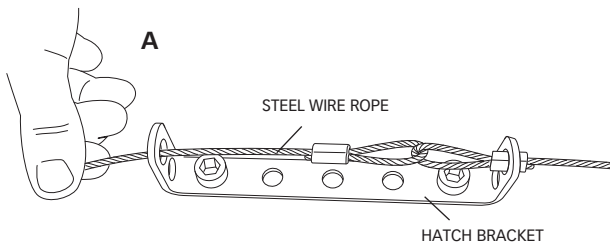


Warning: when manually releasing the actuator the thruster with its weight comes out completely, hence make sure that no one is within its operating range.

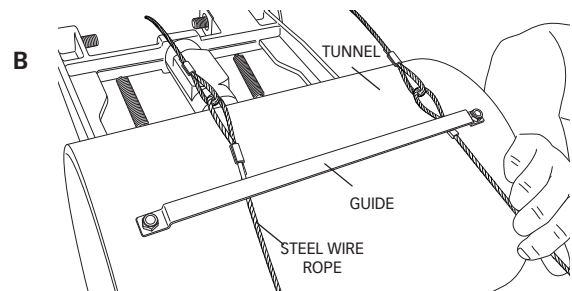


4.6 - Installing the cable in the hatch

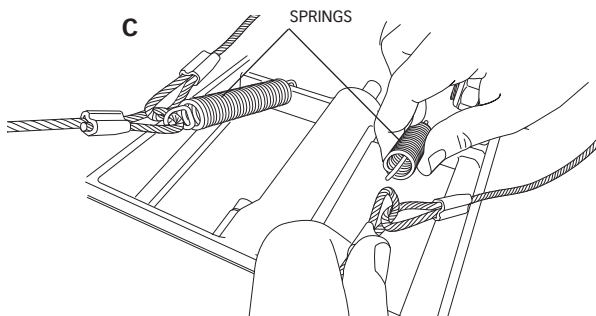
Fig. 17



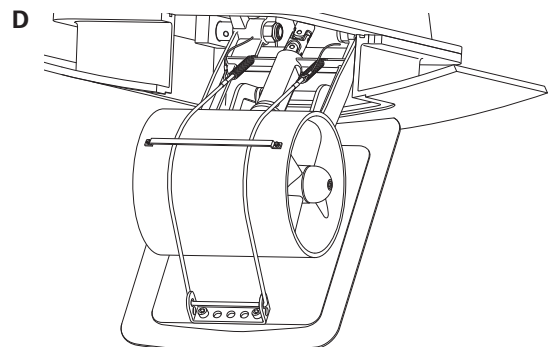
- Insert one end of the cable into the hatch bracket (ref. A).



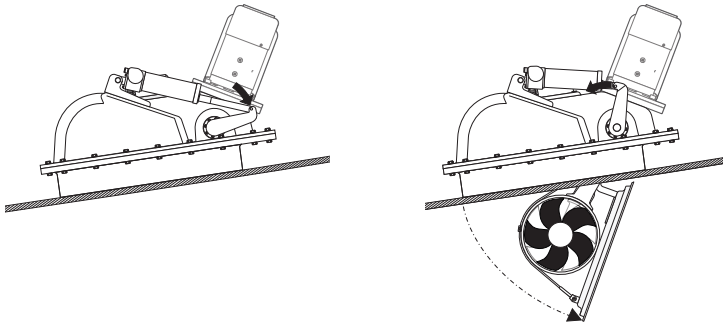
- Run the cable under the guide attached to the tunnel (ref. B)



- Hook the ends of the cable to the two springs (already positioned on the tilting body) (ref. C).



- Final installation of the cable in the hatch (ref. D).



Make sure the system can be closed and opened again smoothly without mechanical hindrance.

4.7 - Adjustment procedure



WARNING: the following procedure must be performed by qualified personnel.



WARNING: presence of moving mechanical parts. Take special care when operating on a powered retractable thruster.

- Make sure that all electrical connections have been made correctly.
- Remove the cover from the RTC R1 board housing (fig.18).
- Switch to "manual mode" to adjust the limit switches.
- Press and hold down both the UP and DOWN buttons on the board (fig. 19) to power the RTC R1 electronic board until the POWER LED (green) flashes rapidly (fig. 19 ref. A). Then release both buttons.
- Now it is possible to control the actuator electrically with the UP and DOWN buttons.
- Press the DOWN button until reaching a stroke that allows the actuator to be hooked to the lever (point 4.5 - fig. 16 ref. A).
- Pressing the DOWN button opens the thruster until the limit switch is activated and the STATUS LED turns green (fig. 19 ref. B).
- The limit switch can be adjusted (point 4.8) if not in the right position (fig. 20A).

Fig. 18

RTC R1

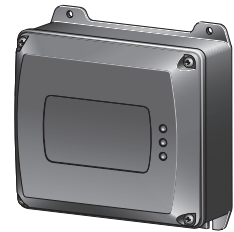
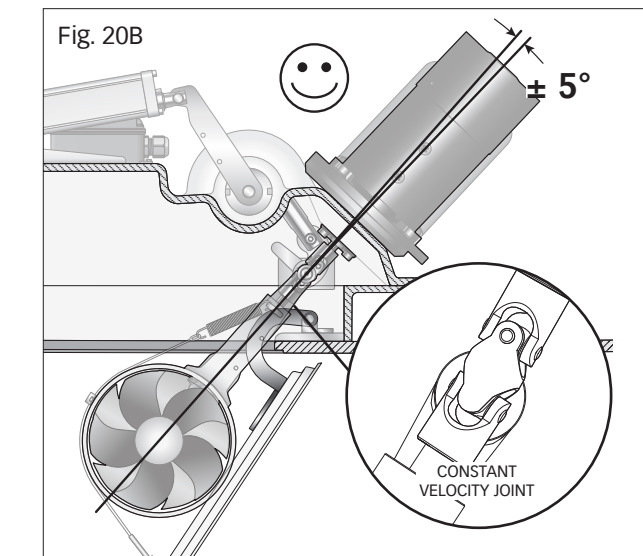
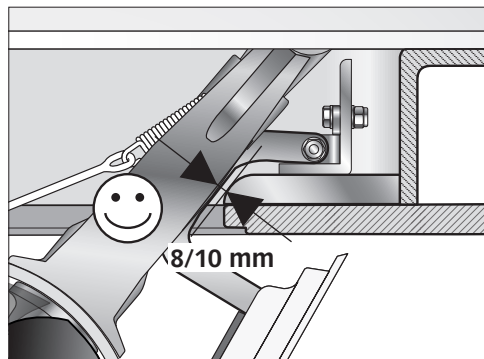
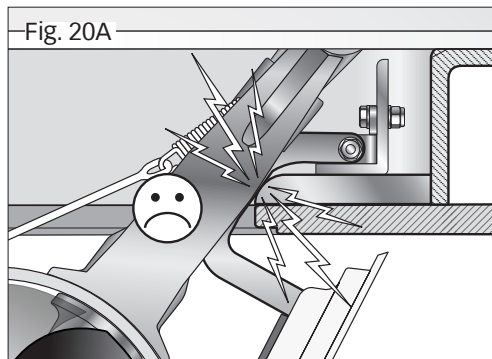
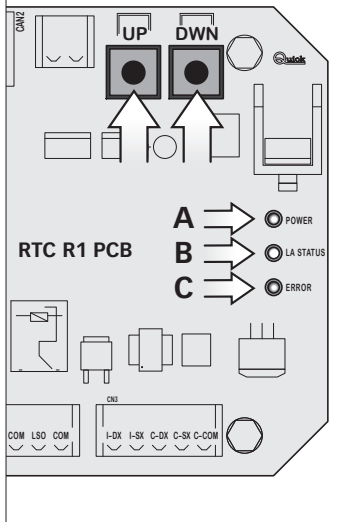


Fig. 19



WARNING: check that the CV joint is in a straight position, at an angle between -5° and +5° (Fig.20b)

- By pressing the UP button it is now possible to verify hatch closing and once the limit switch is reached, the STATUS LED turns red. If the stroke is not enough to reach the limit switch, adjust the latter during closing (point 4.8).



The retractable thruster is factory-set, so it should not be necessary to adjust it during closing.

4.8 - Actuator adjustment

Opening the side door of the actuator. Fig.21A
Actuator internal view. Fig.21B

Fig.21A

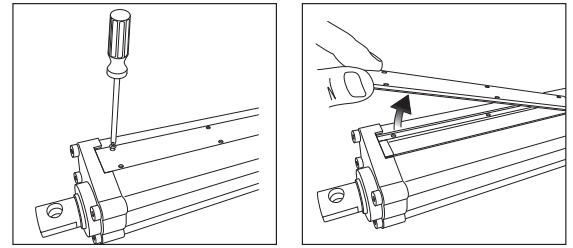
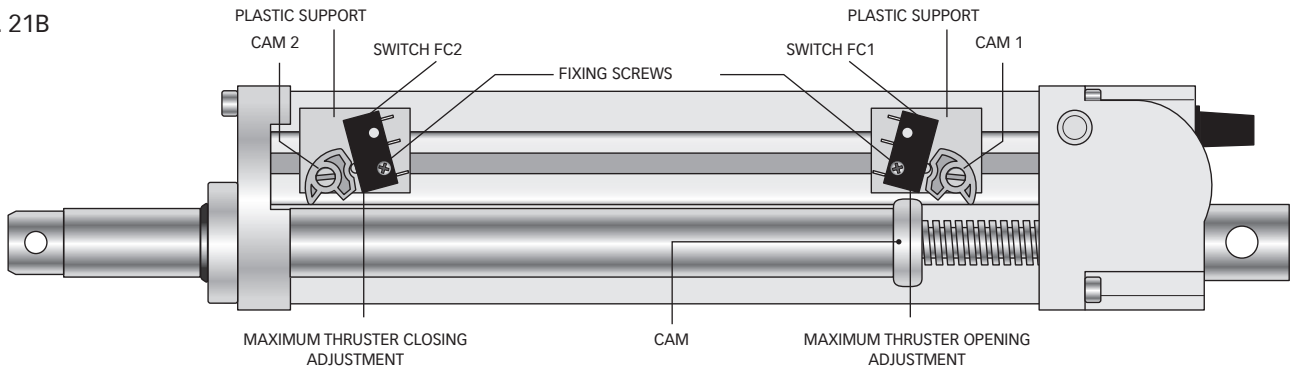


Fig. 21B



- To adjust the FC1 and FC2 limit switches, slightly loosen the fixing screw and move them to the right or left as needed. Then tighten the fixing screw back (fig. 21B).



WARNING: during each adjustment of the FC1 and FC2 limit switches, check that the cam that operates them is always positioned between them and never over the required stroke.

- Disconnect the retractable thruster from the power supply for at least five seconds (fig. 22).
- Power the retractable thruster again (fig. 22).
- Enable a TCD control connected to the retractable thruster to open the hatch and make it operational (fig. 23).
- Disable the previously enabled TCD control to close the retractable thruster (fig. 23).
- Make sure that the thermal cut-out has not tripped (the ERROR LED must be off - see point 4.7 fig. 19/Ref. C).

Fig. 22

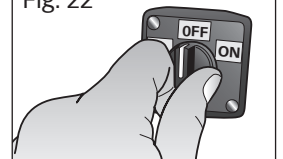


Fig. 23



4.9 - Installing spring end-of-stroke cables

- Open the hatch completely via the control (fig. 23).

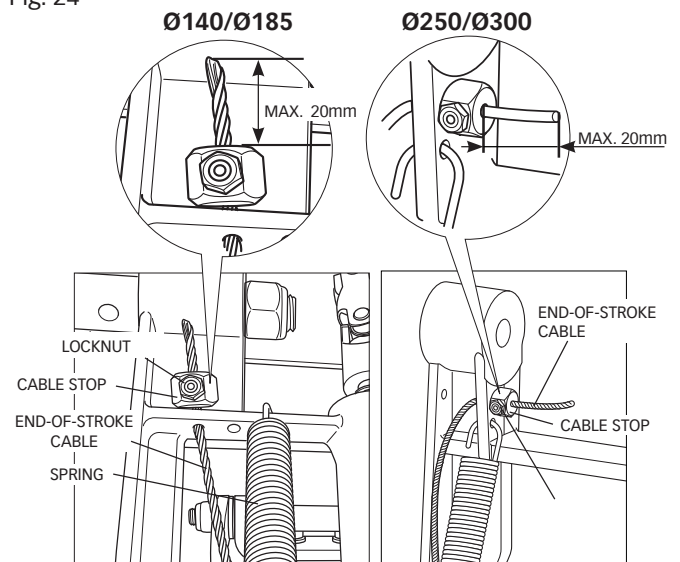


WARNING: Once the hatch has been opened, turn off the power (fig. 22) to lock it in this position.

Fig. 24

- Insert the two end-of-stroke cables into the appropriate seats.
- Place the two cable stops, tension the two cables, making sure that both springs are tensioned at the same length, and tighten the cable stops with a 2.5mm Allen wrench.
- Secure the cable stop by tightening the locknut with an 8 mm fork wrench, cut the excess cable with wire cutters leaving approx. 20mm beyond the cable stop.
- Power the retractable thruster (fig. 22) which will automatically close.
- To ensure correct operation, open the hatch a few times via the control (fig. 23).

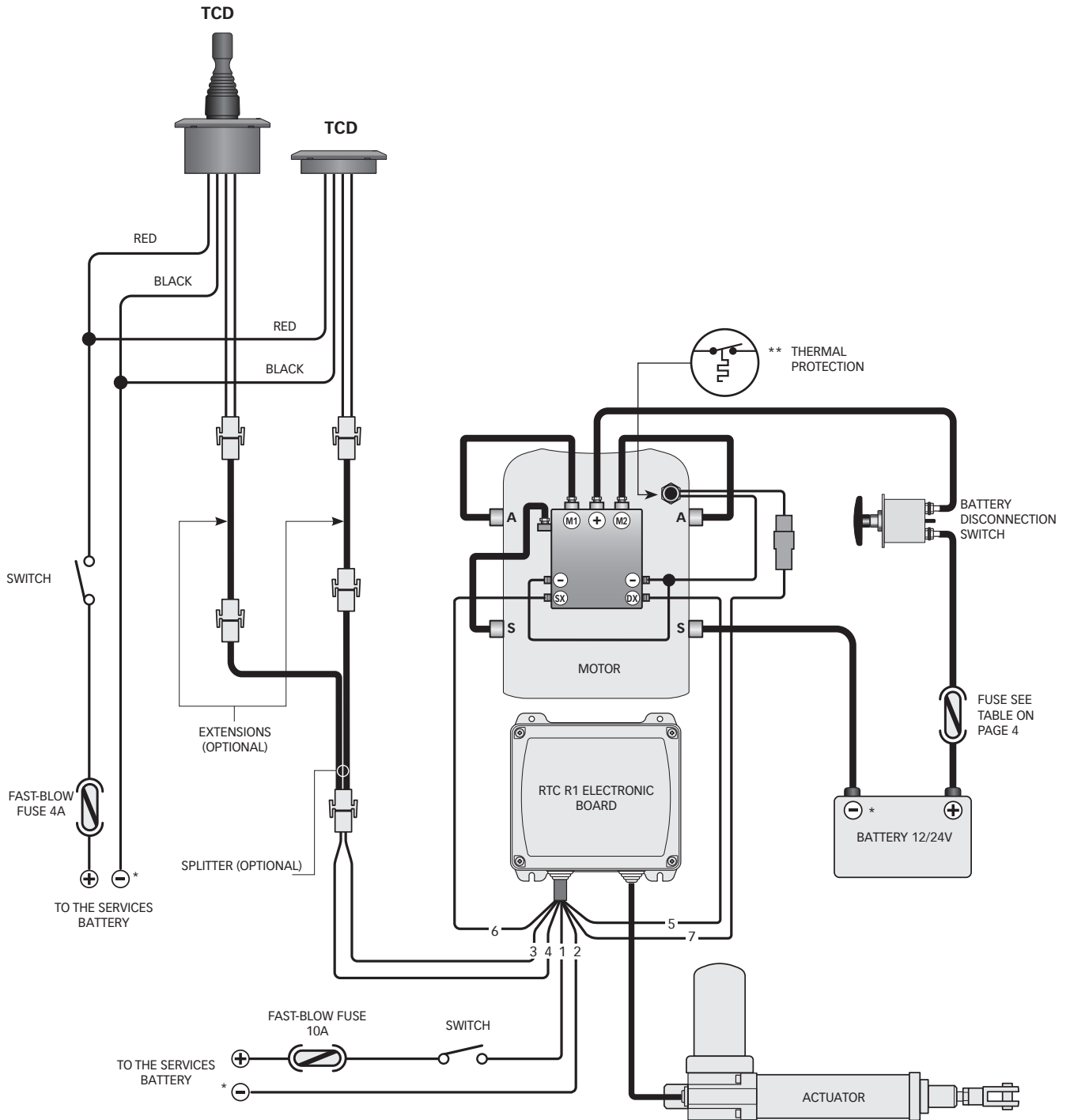
Fig. 24





5.0 - BTR basic system

Example of connection

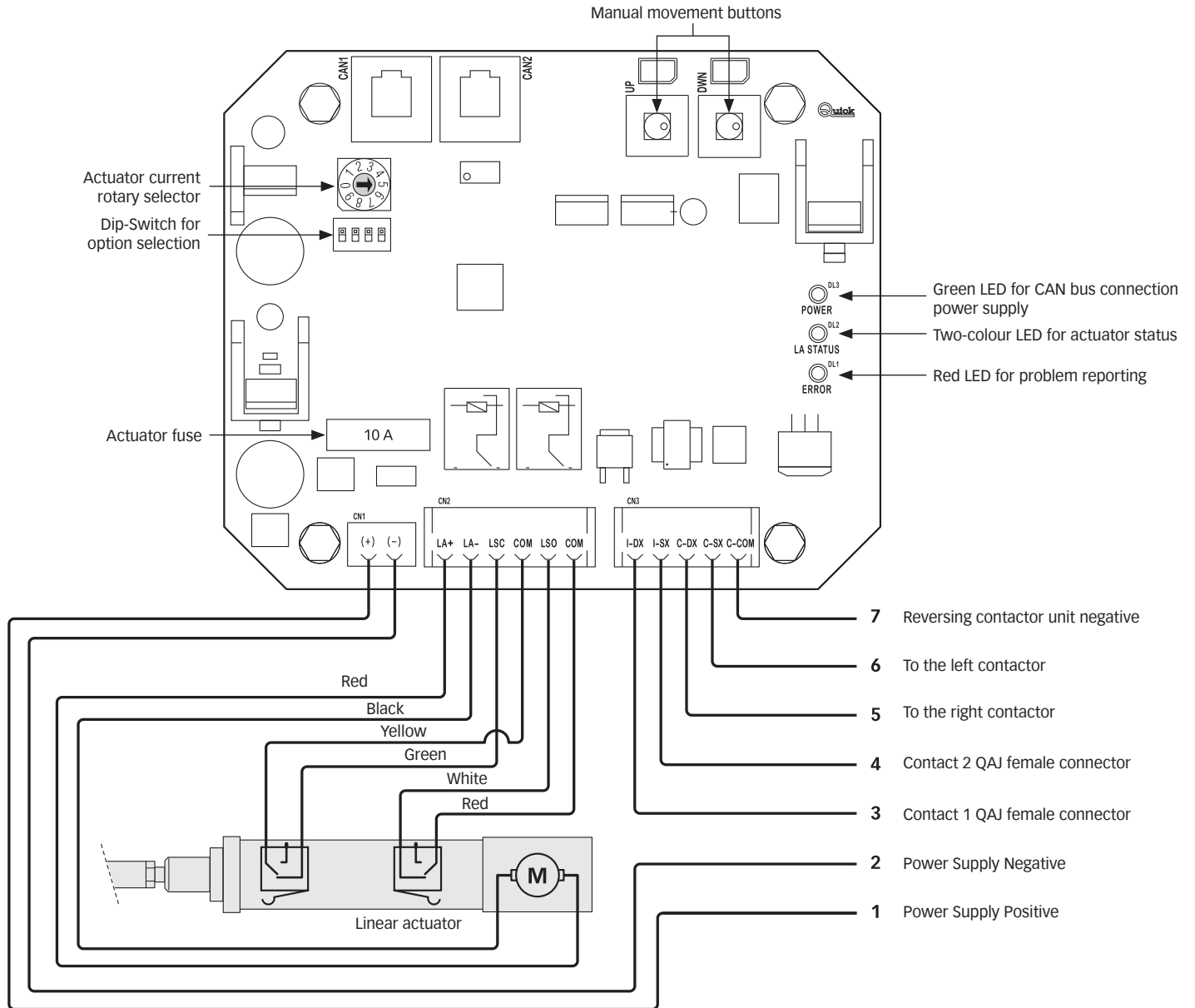


* COMMON NEGATIVE FOR BATTERY GROUPS.

**WARNING: IN CASE OF OVERTEMPERATURE, THE THERMAL CUT-OUT ON THE MOTOR WILL TRIGGER AND INTERRUPT THE NEGATIVE CONTACT ON THE CONTACTOR. WAIT FOR THE TIME NEEDED FOR REACTIVATION.

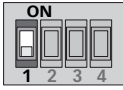
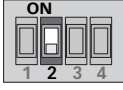






5.1 - RTC R1 board





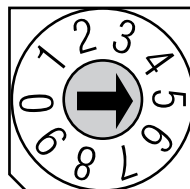
6.0 - Dip-Switch for option selection

SELECTION	FUNCTION	DIP-SWITCH
1	Reserved (always keep off)	
2	It indicates to the CAN control station that the thruster is in the bow (OFF)	
	It indicates to the CAN control station that the thruster is in the stern (ON)	
3	Reserved (always keep off)	
4	Reserved (always keep off)	
FACTORY SETTING: 1 = OFF, 2 = OFF, 3 = OFF, 4 = OFF		

6.1 - Actuator current rotary selector

The ten selectable steps (from 0 to 9) allow you to set a percentage referring to the “maximum current/load” allowed for the actuator in use (see table).

ROTARY SELECTOR POSITION	MAXIMUM CURRENT/LOAD %
0	28%
1	36%
2	44%
3	52%
4	60%
5	68%
6	76%
7	84%
8	92%
9	100%



If a setting other than the factory setting is required, proceed as follows:

- 1) With the board not powered, place the arrow of the rotary selector in the desired position.
- 2) After powering the board again, the percentage corresponding to the selected position will be automatically set.

If the maximum current/load limit is too low compared to the real needs of use, the thermal cut-outs of the actuator may be tripped during retractable thruster closing and opening with error 1 and 7 flashing.

7.0 - Light signals

Below is the meaning of the light signals provided by the RTC R1 board (see electronic board on page 13).

POWER LED (GREEN)

LED STATUS	DESCRIPTION
OFF	Board not powered
FLASHING SHORTLY	Board powered but control not enabled
FLASHING FAST	Board powered and active manual actuator movement mode
ON WITH SHORT SHUTDOWN	Board powered but control not enabled and link active with CAN control station
ON	Board powered and control enabled (TCD or CAN station).

LA STATUS LED (TWO-COLOUR)

LED COLOUR	LED STATUS	DESCRIPTION
-	OFF	With board powered, active manual actuator movement mode and limit switch fault present
RED	ON	Retractable unit closed (active LSC limit switch)
GREEN	ON	Retractable unit open (active LSO limit switch)
ORANGE	ON	Retractable unit neither open nor closed (LSC and LSO limit switches not active)
ORANGE	FLASHING	Retractable unit neither open nor closed (LSC and LSO limit switches not active) and linear actuator in motion.

ERROR LED (RED)

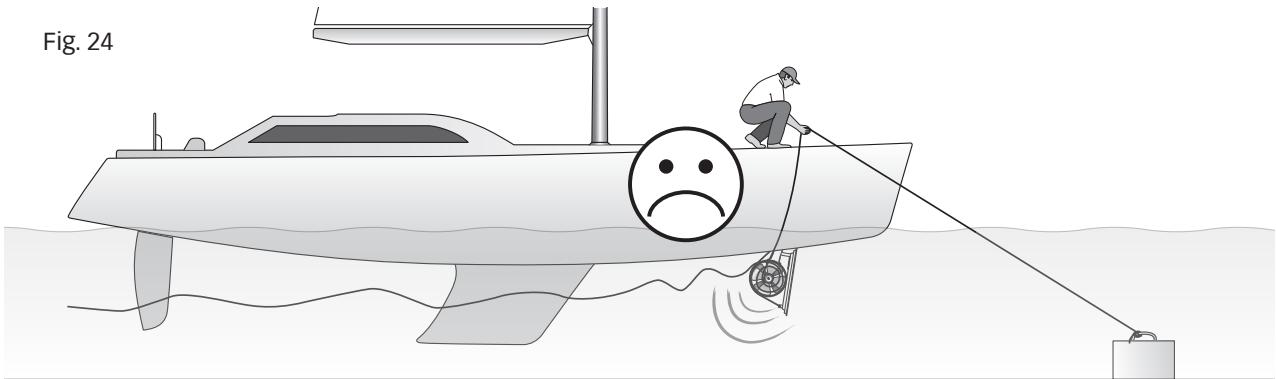
NUMBER OF FLASHES	DESCRIPTION
NONE	No fault detected.
1	High rising actuator absorption (retractable unit closing). The signal is triggered after the system has made three attempts to rise in the presence of mechanical friction above the set threshold. The problem can be caused by a foreign body entering the mechanism, the boat sailing at high speed, or mechanical problems with the retractable thruster and its hatch.
2	Fuse open. A current absorption greater than 10A has occurred. The problem may occur if there is a short circuit or overload on the actuator power line. Check the wiring of the power lines from the board to the actuator or the absorption of the actuator itself.
3	Abnormal limit switch condition. The problem is reported if the board detects a fault on the limit switches (both activated). Check the power line wiring from the board to the limit switches and their operation.
4	Actuator control line interruption. The problem is reported if the board detects an interruption in the actuator control power line. Check the wiring of the power lines from the board to the actuator.
5	Actuator movement timeout tripped. The problem is reported if the movement imparted to the actuator is not carried out within a period of 15 seconds.
6	Incorrect dip-switch configuration. The problem is reported if the dip-switch positions are not set correctly.
7	High lowering actuator absorption (retractable unit opening). The signal is triggered after the system has made three attempts to lower in the presence of a mechanical friction above the set threshold. The problem can be caused by a foreign body entering the mechanism, the boat sailing at high speed, or mechanical problems with the retractable thruster and its hatch.
8	High absorption of motor reversing contactor control output. The problem is reported if the board detects a short circuit or overload on the motor control power line. Check the wiring of the power lines from the board to the motor and the absorption of the reversing contactor/motor unit installed on the retractable thruster.
9	Motor thermal cut-out tripped. The problem is reported if the thermal cut-out of the motor has tripped. Wait for it to cool down.
	Interruption of motor reversing contactor control output connection. The problem is reported if the board detects an interruption in the motor control power line. Check the wiring of the power lines from the board to the reversing contactor/motor unit installed on the retractable thruster.

8.0 - Important cautions



- This thruster is not designed for continuous use. It is equipped with protections which limit its operation at a maximum time span, as reported on the controls' manual. It is strongly forbidden to bypass or modify such protections in order to increase the operating time span, as these actions will void the warranty, thus lifting any responsibility from Quick® SPA.
- Make sure no swimmers or floating objects are in the vicinity before switching on the retractable thruster.
- In order not to damage the system, it is recommended to avoid navigating with the retractable thruster open and to open and close the thruster within a maximum speed of 4 knots and to proceed in reverse at a maximum speed of 2 knots, always taking into account the currents.
- In order not to damage the system, it is also recommended not to enable the thruster at speeds exceeding four knots.
- There must not be flammable materials in the peak or in the area where the Bow Thruster motor is.
- During mooring, it is recommended not to leave in the water any free line, which may be sucked in by the thrusters, thus leading them to break (fig. 24).

Fig. 24



9 - Use

BTR Series

9.0 - Retractable thruster use

To use the retractable thruster, refer to the TCD control manual

Start-up

When powered on, the RTC R1 board checks the position of the retractable thruster (raised, lowered, or in intermediate position). In the event that it is raised, the system does not perform actions.

In the event that it is lowered or in an intermediate position, it will control the rise of the retractable thruster.

Enabling control from TCD (Retractable thruster lowering)

When the RTC R1 board is enabled by a TCD control, the retractable thruster lowering procedure begins.

The right/left commands coming from the TCD will be inhibited until the procedure is completed.

During the lowering phase, the RTC R1 board measures the current drawn by the linear actuator.

If due to mechanical friction there is a high absorption of the linear actuator, the lowering will be reversed for a short time and then resumed. The RTC R1 board will report the problem after 3 attempts.

Disabling control from TCD (Retractable thruster rising)

When the RTC R1 board is disabled by a TCD control, the retractable thruster rising procedure begins.

On the way up, the right/left commands coming from the TCD will be inhibited.

During the rising phase, the RTC R1 board measures the current drawn by the linear actuator.

If due to mechanical friction there is a high absorption of the linear actuator, the rising will be reversed for a short time and then resumed. The RTC R1 board will report the problem after 3 attempts.

Automatic rising in case of TCD time-out

With the thruster down, the retractable thruster performs the rising procedure after 6 minutes from the last right or left command of the TCD.

Error detection from the TCD

If the TCD sends an error signal into the network (extended command, line interruption, short circuit on the right or left output), the retractable thruster performs the rising procedure.

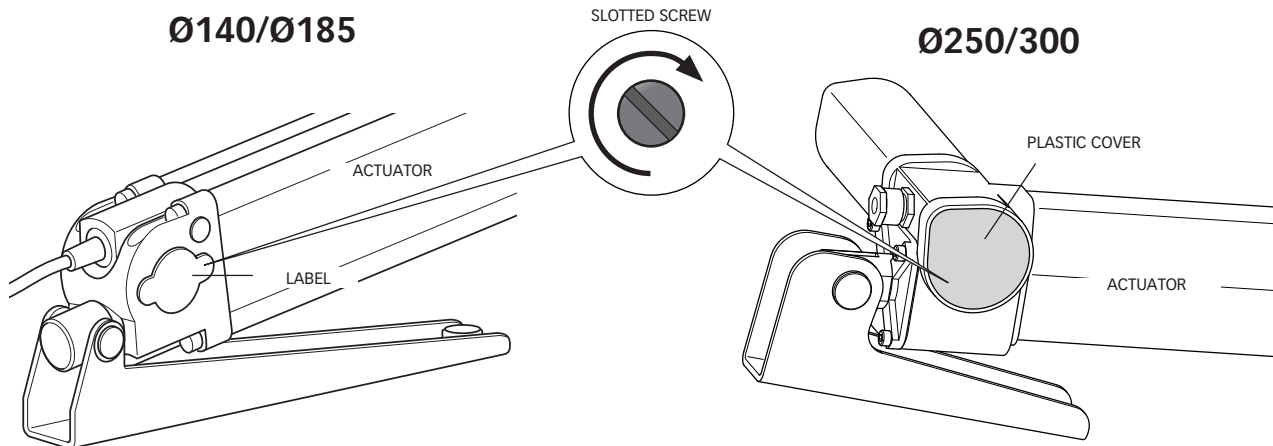


9.1 - Manual closing of the thruster in case of emergency

There is a slotted screw on the actuator, under the label (Ø185) or under the cover (Ø250/Ø300); turn it clockwise to close the system.



WARNING: Cut off the power to the retractable thruster.



10 - Maintenance

BTR Series

Quick® Thrusters are made in materials that are resistant to the sea environment: in any case, it is indispensable to periodically remove salt deposits that form on the outer surfaces to avoid corrosions with consequent system inefficiency.



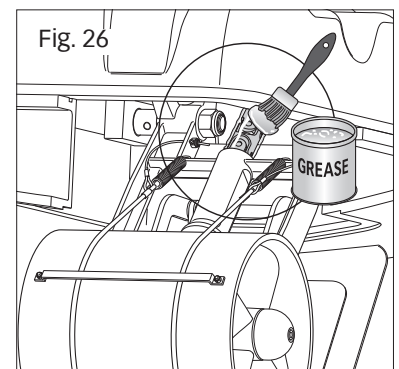
WARNING: make sure that the power supply to the electric motor is not switched on when maintenance operations are carried out.



DEPENDING ON USE, PERIODICALLY CHECK THE TIGHTNESS OF THE OIL SEALS AND REPLACE THEM IF NECESSARY.

Dismantle once a year, following the points below:

- Clean propellers, tunnel and gearleg.
- Replace the propellers if damaged or worn out.
- Replace the anodes (replace more frequently if necessary) and, if possible, lubricate the CV joint with marine grease (fig. 26).
- Check the tightness of all screws.
- Ensure that there is no water seepage inside.
- Check that all electrical connections are well tightened and oxide-less.
- Check that the batteries are in good conditions
- Eliminate any graphite residues produced by the normal wear of the motor brushes.



WARNING: do not paint the anodes, the seals and the gearleg shafts where the thrusters are lodged.



11 - Product disposal

BTR Series

As with installation, at the end of this product life, dismantling must be carried out by qualified personnel.

This product is made up of various materials, some can be recycled and others must be suitably disposed of; enquire about the recycling or disposal systems provided for by local regulations for this product category.

Some parts of the product may contain pollutants or hazardous substances that, if dispersed, may be harmful to the environment and human health.



As indicated by the symbol on the side, it is forbidden to dispose of this product as domestic waste.

Separate the products for disposal in accordance with the regulations in force in your area or return the product to the seller when purchasing a new equivalent product.

Local regulations may impose severe penalties for the improper disposal of this product.



BTR 140 Pag.24

NO.	NAME	15	RRC RX CONTAINER	31	PIN	47	CYLINDER HEAD SCREW	63	RETRACTABLE THRUSTER TUNNEL
1	SCREW	16	CABLE GLAND	32	ACTUATOR	48	GROWER	64	ROPE GUIDE
2	GROWER	17	SCREW	33	PIN	49	KEY INSERT	65	WASHER
3	MOTOR	18	WASHER	34	PIVOT	50	TILTING BODY	66	SCREW
4	REVERSING CONTACTOR BOX	19	THREADED INSERT	35	OIL SEAL	51	ANODE	67	GEARBOX GASKET
5	WASHER	20	NUT	36	SNAP RING	52	SCREW	68	REDUCTION GEAR
6	SCREW	21	ANGLE BRACKET	37	BEARING	53	SCREW	69	SCREW
7	REVERSING CONTACTOR BOX GUARD	22	HINGE BRACKET	38	SHAFT	54	GROWER	70	SCREW
8	REVERSING CONTACTOR BOX GUARD FASTENER	23	WASHER	39	SUPPORT	55	SPRING	71	NUT
9	FLANGE	24	SCREW	40	CONSTANT VELOCITY JOINT	56	CABLE STOP	72	ANODE
10	PIN	25	WASHER	41	SCREW	57	SCREW	73	SCREW
11	SCREW	26	HINGE ARM	42	WASHER	58	NUT	74	SCREW
12	FIXING RING	27	HATCH BRACKET	43	NUT	59	BEARING	75	CABLE
13	OIL SEAL	28	HINGE SHAFT	44	OIL SEAL	60	KEY		
14	O-RING	29	ACTUATOR LEVER	45	OIL SEAL	61	SHAFT		
		30	HINGE SHAFT	46	EXTERNAL SNAP RING	62	O-RING		

BTR 185 Page 25

NO.	NAME	18	OIL SEAL	37	HATCH BRACKET	55	PIVOT	74	GASKET
1	SCREW	19	KEY	38	OIL SEAL	56	SCREW	75	KEY
2	GROWER	20	ACTUATOR LEVER	39	INTERNAL SNAP RING	57	ANODE	76	GEARLEG
3	MOTOR	21	ACTUATOR PLATE	40	BEARING	58	SCREW	77	PIN
4	REVERSING CONTACTOR BOX	22	CABLE GLAND	41	SHAFT	59	CABLE STOP	78	THRUSTER 185 R
5	WASHER	23	SCREW	42	KEY	60	SCREW	79	THRUSTER 185 L
6	SCREW	24	RRC RX CONTAINER	43	WASHER	61	NUT	80	NUT
7	REVERSING CONTACTOR BOX GUARD	25	PIN	44A	BEARING	62	TILTING BODY	81	ANODE
8	REVERSING CONTACTOR BOX GUARD FASTENER (NUT)	26	SPRING RING	44B	BEARING	63	PIN	82	SCREW
9	SCREW	27	ACTUATOR	45	SHAFT SUPPORT	64	NUT	83	TUNNEL
10	SCREW	28	SCREW	46	OIL SEAL	65	LEVER	84	ROPE GUIDE
11	FLANGE	29	PIVOT	47	EXTERNAL SNAP RING	66	LEVER	85	WASHER
12	CHASSIS	30	PIN	48	PLATE	67	EXTERNAL SNAP RING	86	SCREW
13	SCREW	31	ANGLE BRACKET	49	CONSTANT VELOCITY JOINT	68	SCREW	87	SELF-LOCKING NUT
14	WASHER	32	HINGE BRACKET	50	EXTERNAL SNAP RING	69	SPRING	88	SELF-LOCKING NUT
15	NUT	33	HINGE SHAFT	51	OIL SEAL	70	SHAFT	89	CABLE
16	O-RING SEAL	34	SCREW	52	NUT	71	SCREW		
17	O-RING	35	WASHER	53	SHAFT	72	GROWER		
		36	HINGE ARM	54	SHAFT	73	O-RING		

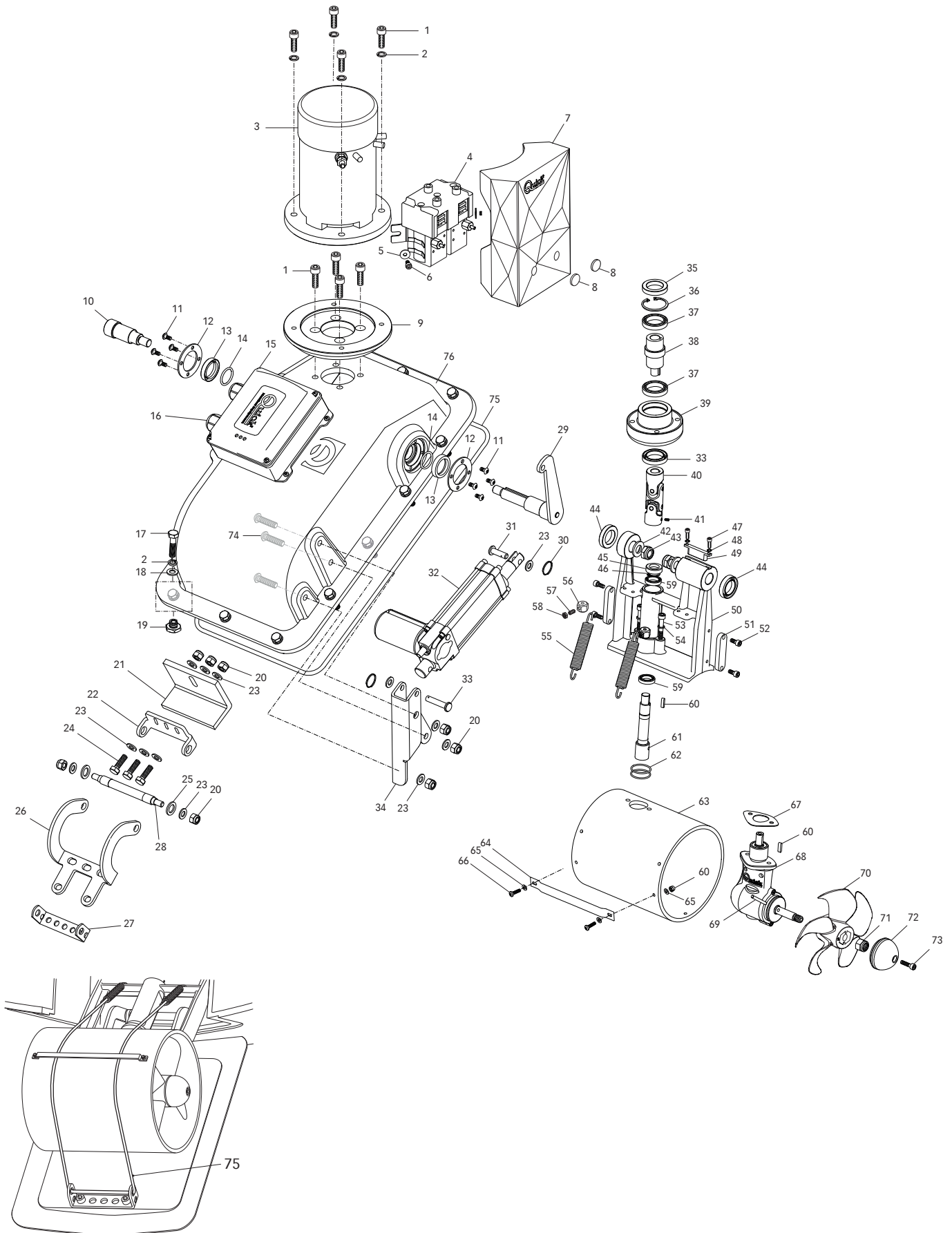
BTR 250 Pag.26

N	NAME	17	PIN	35	BEARING	53	BEARING	71	WASHER
1	SCREW	18	WASHER	36	EXTERNAL SNAP RING	54	INTERNAL SNAP RING	72	NUT
2	GROWER	19	SPRING RING	37	SHAFT SUPPORT	55	EXTERNAL SNAP RING	73	NUT
3	MOTOR	20	RRC RX CONTAINER	38	OIL SEAL	56	OIL SEAL	74	SCREW
4	REVERSING CONTACTOR BOX	21	CABLE GLAND	39	CONSTANT VELOCITY JOINT	57	CABLE STOP	75	ROPE GUIDE
5	REVERSING CONTACTOR BOX GUARD	22	SCREW	40	TILTING BODY	58	TILTING BODY	76	HINGE SHAFT
6	REVERSING CONTACTOR BOX GUARD FASTENER	23	WASHER	41	SPRING	59	NUT	77	HINGE BRACKET
7	KEY	24	ACTUATOR BRACKET	42	ANODE	60	SHAFT	78	WASHER
8	SCREW	25	PIN	43	SCREW	61	TUNNEL	79	HINGE ARM
9	FLANGE	26	SELF-LOCKING NUT	44	SCREW	62	GASKET	80	HATCH BRACKET
10	CHASSIS	27	ACTUATOR	45	GROWER	63	REDUCTION GEAR	81	SCREW
11	O-RING	28	SCREW	46	OIL SEAL	64	KEY	82	ANGLE BRACKET
12	OIL SEAL	29	ACTUATOR PLATE	47	KEY INSERT	65	THRUSTER 250 R	83	WASHER
13	RING	30	O-RING	48	GROWER	66	THRUSTER 250 L	84	SELF-LOCKING NUT
14	SCREW	31	OIL SEAL	49	SCREW	67	ANODE	85	CABLE
15	PIN	32	INTERNAL SNAP RING	50	WASHER	68	WASHER		
16	ACTUATOR LEVER	33	SHAFT	51	NUT	69	SCREW		
		34	KEY	52	O-RING	70	SCREW		

BTR 300 Pag.27

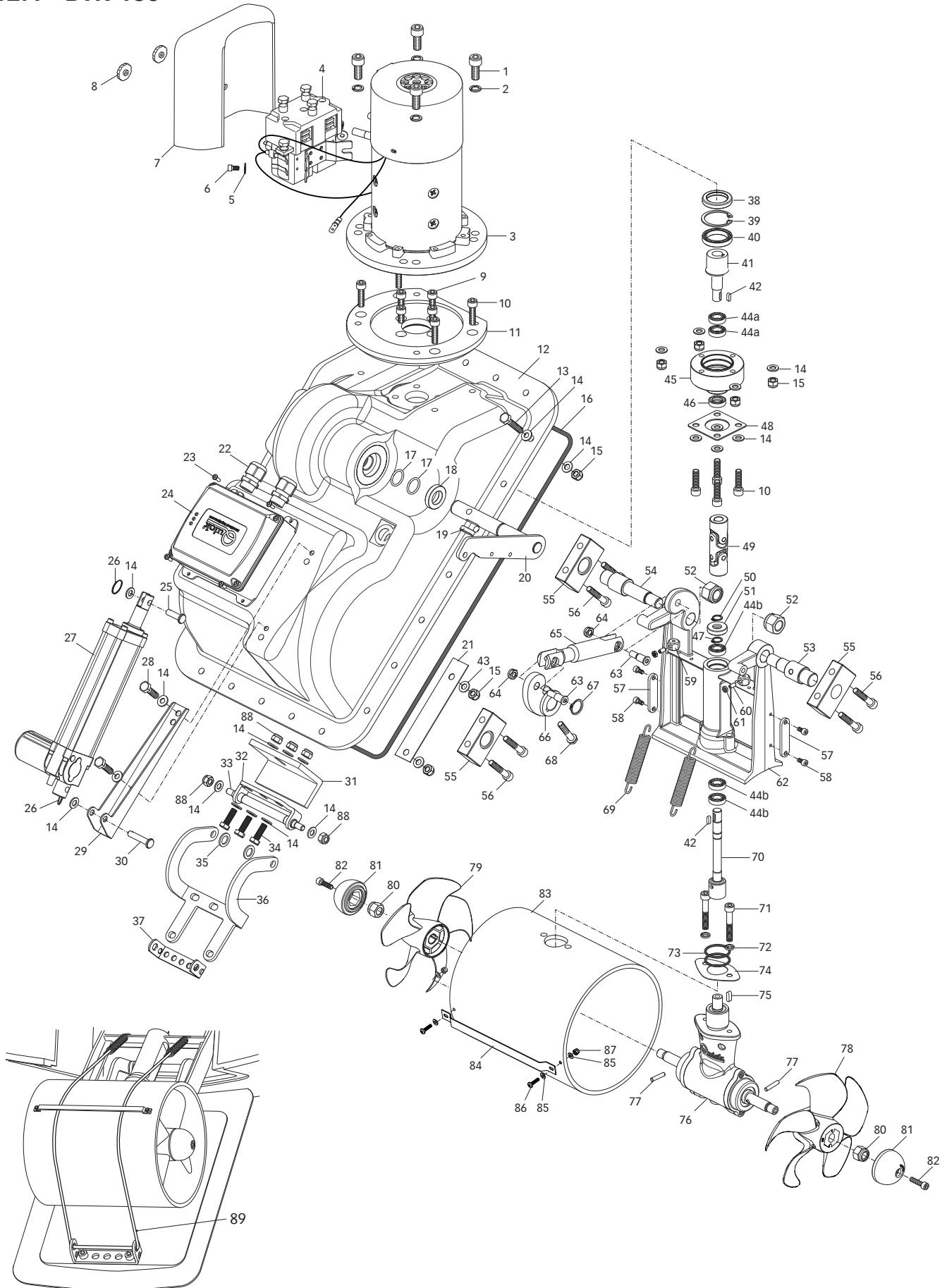
N	NAME	17	WASHER	35	SHAFT SUPPORT	54	OIL SEAL	74	SELF-LOCKING NUT
1	SCREW	18	SPRING RING	36	OIL SEAL	55	CABLE STOP	75	COUNTER FLANGE
2	GROWER	19	RRC RX CONTAINER	37	CONSTANT VELOCITY JOINT	56	SCREW	76	WASHER
3	MOTOR	20	CABLE GLAND	38	TILTING BODY	57	NUT	77	NUT
4	REVERSING CONTACTOR BOX	21	SCREW	39	SPRING	58	SHAFT	78	HINGE SHAFT
5	REVERSING CONTACTOR BOX GUARD	22	WASHER	40	ANODE	59	TUNNEL	79	HINGE BRACKET
6	REVERSING CONTACTOR BOX GUARD FASTENER	23	ACTUATOR BRACKET	41	SCREW	60	GASKET	80	WASHER
7	SCREW	24	PIN	42	STUD	61	REDUCTION GEAR	81	HINGE ARM
8	FLANGE	25	SCREW	43	GROWER	62	KEY	82	HATCH BRACKET
9	CHASSIS	26	ACTUATOR	44	OIL SEAL	63	THRUSTER 250 R	83	SCREW
10	O-RING	27	ACTUATOR PLATE	45	KEY INSERT	64	THRUSTER 250 L	84	ANGLE BRACKET
11	OIL SEAL	28	NUT	46	GROWER	65	ANODE	85	WASHER
12	RING	29	OIL SEAL	47	SCREW	66	SCREW	86	SELF-LOCKING NUT
13	SCREW	30	INTERNAL SNAP RING	48	WASHER	69	WASHER	87	KEY
14	PIN	31	SHAFT	49	NUT	70	SCREW	88	ADAPTER
15	ACTUATOR LEVER	32	KEY	50	O-RING	71	NUT	89	CABLE
16	PIN	33	BEARING	51	BEARING	72	SCREW		
		34	EXTERNAL SNAP RING	53	EXTERNAL SNAP RING	73	ROPE GUIDE		

12.0 - BTR 140

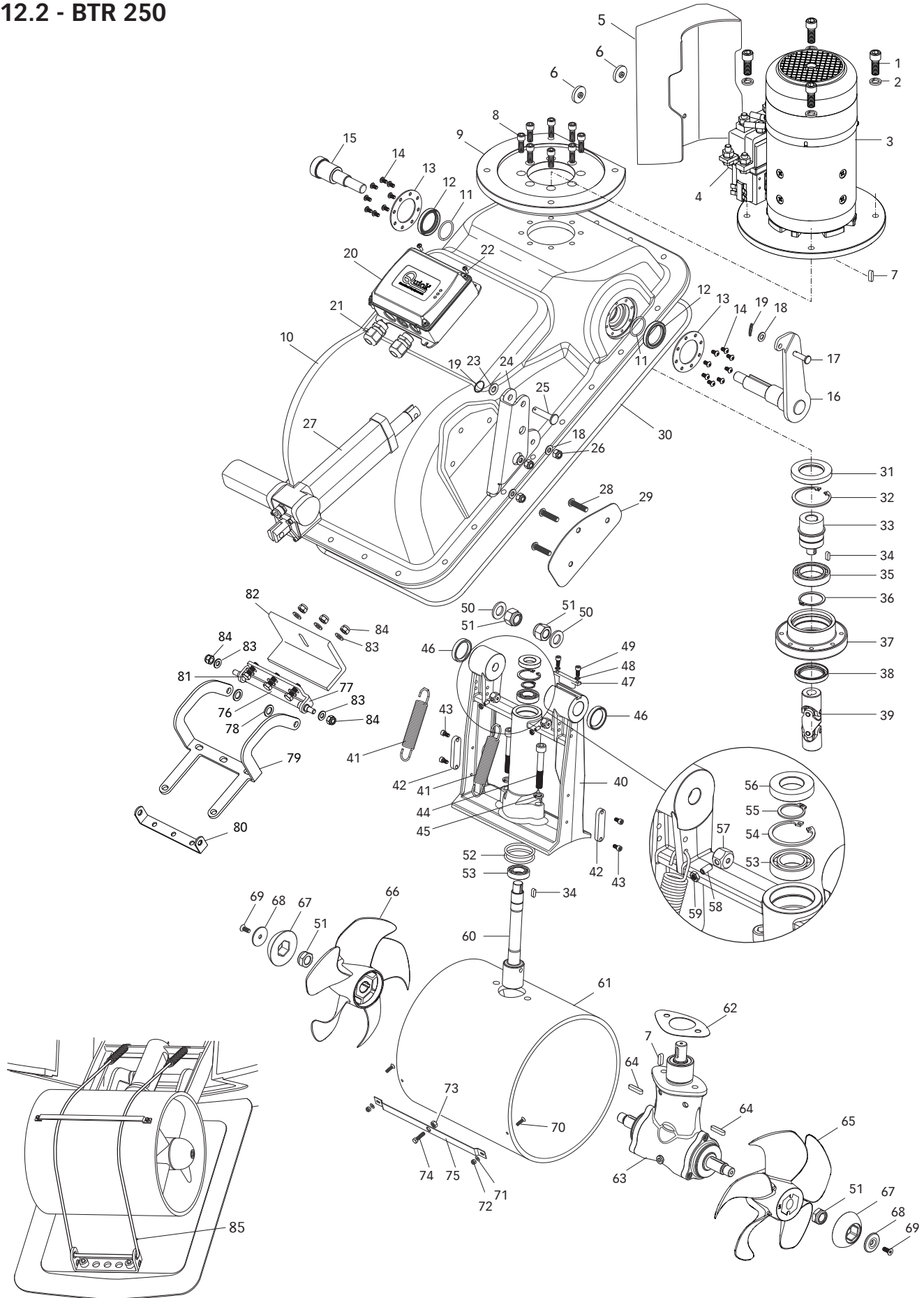




12.1 - BTR 185

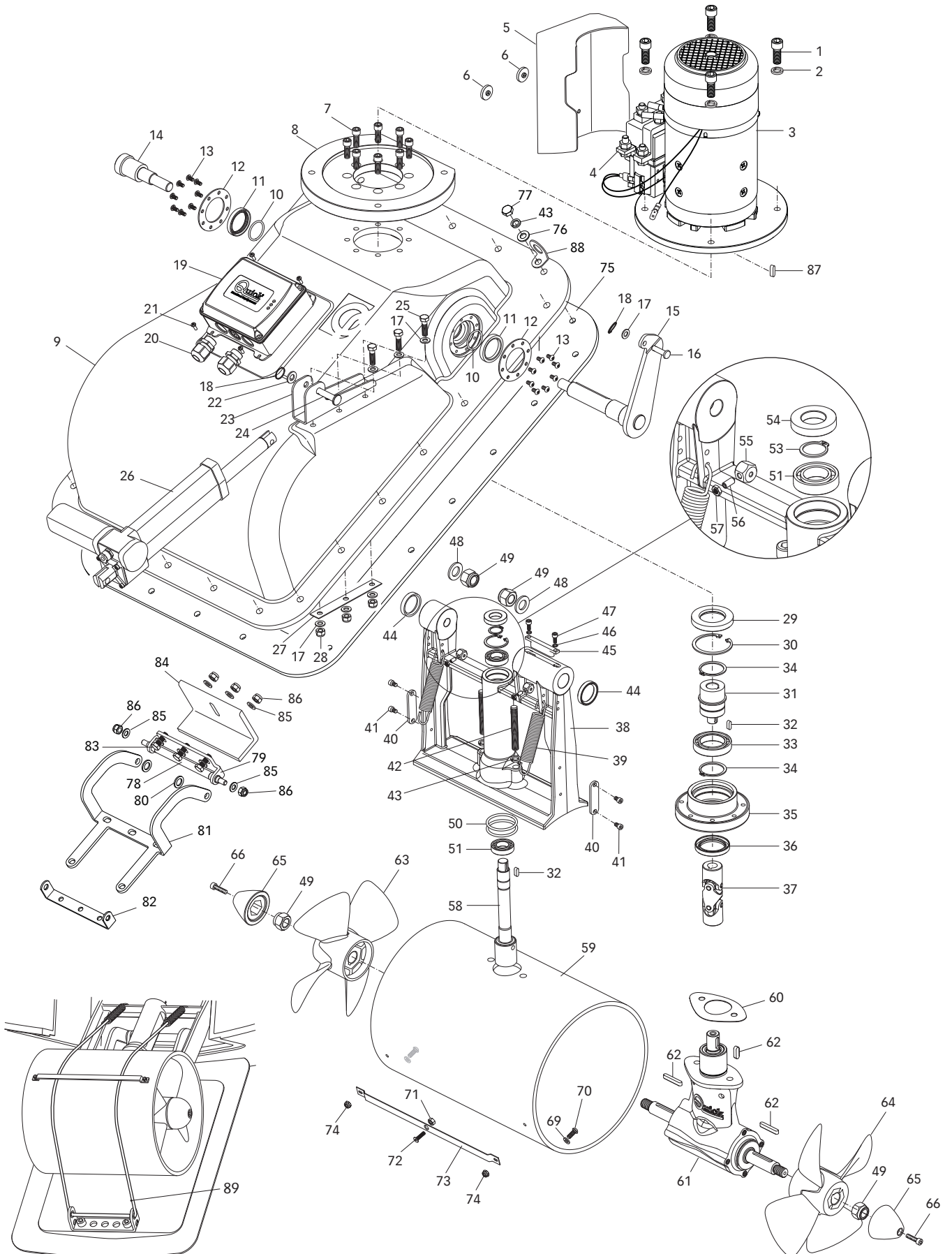


12.2 - BTR 250



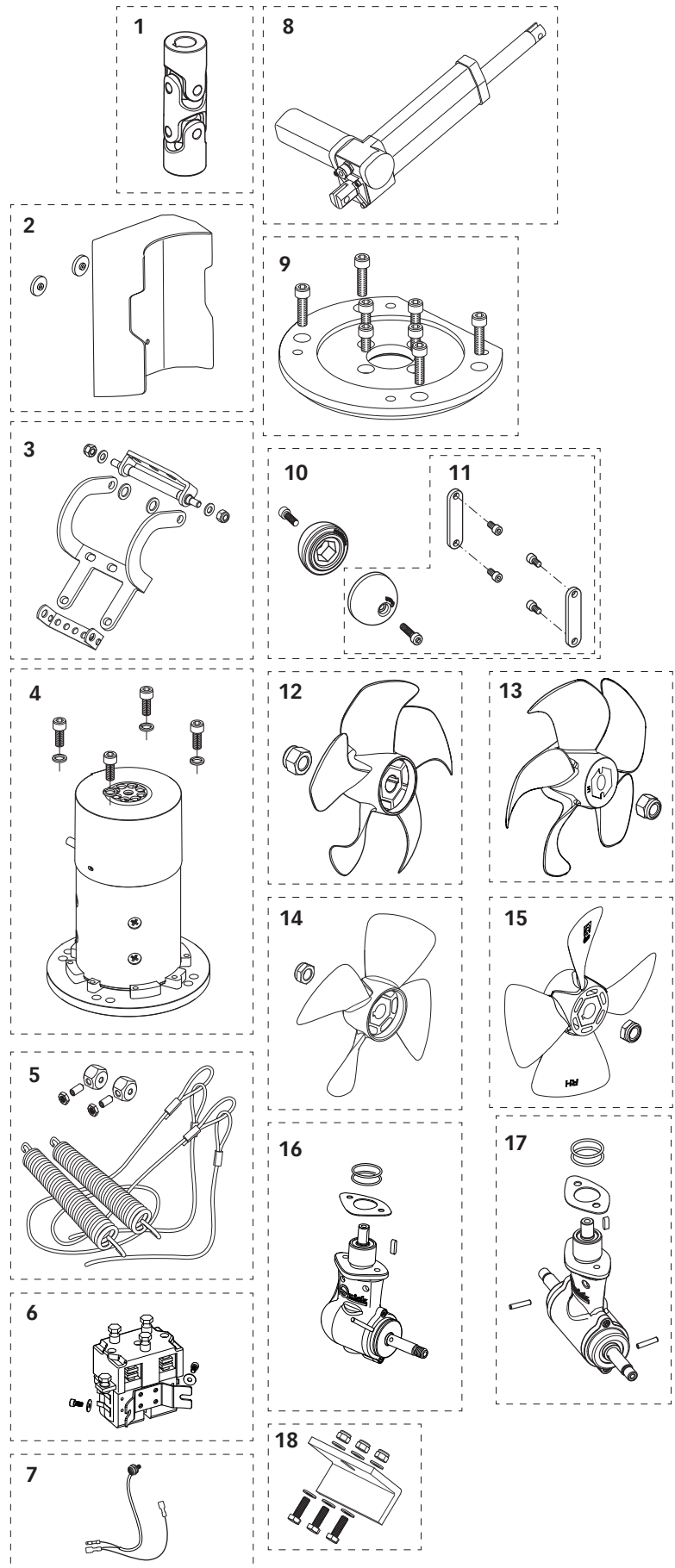


12.3 - BTR 300



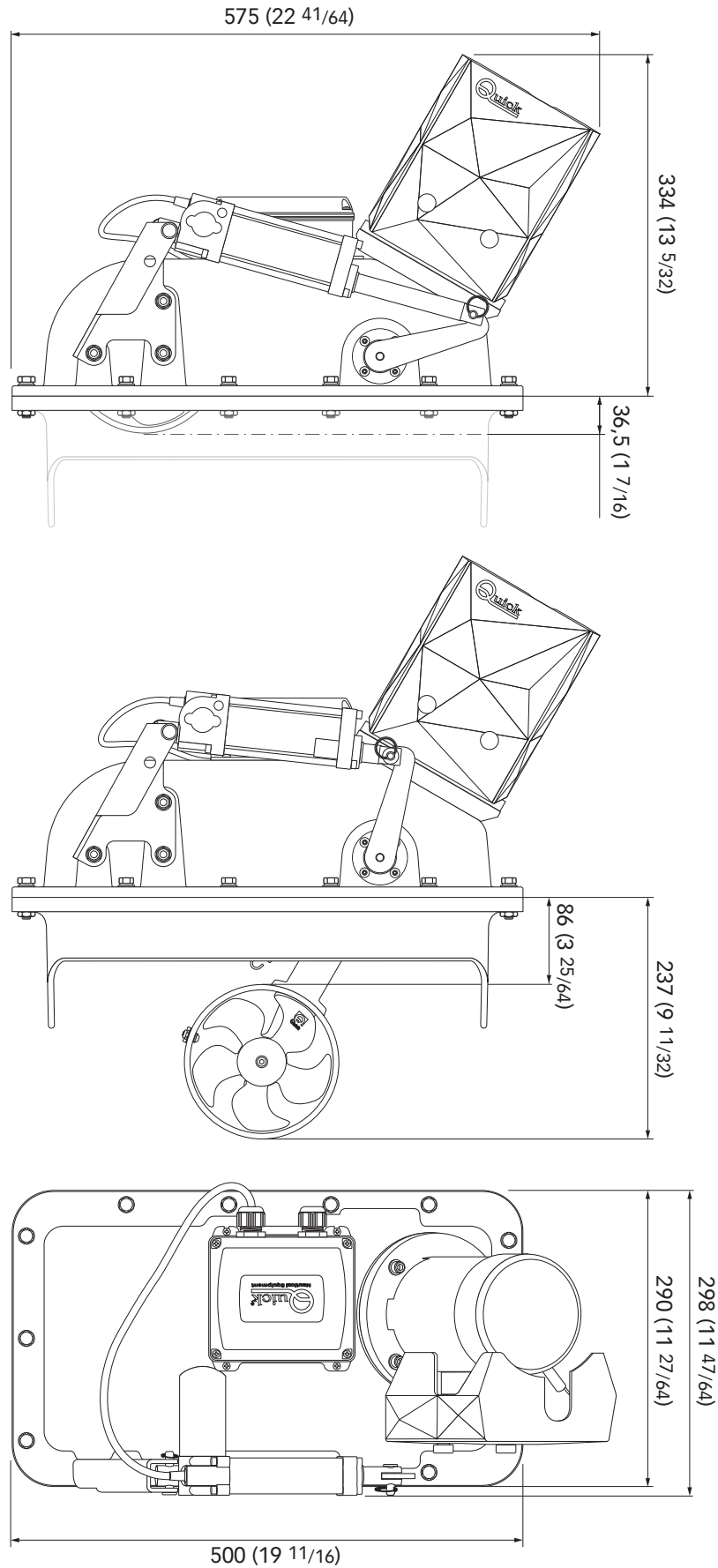


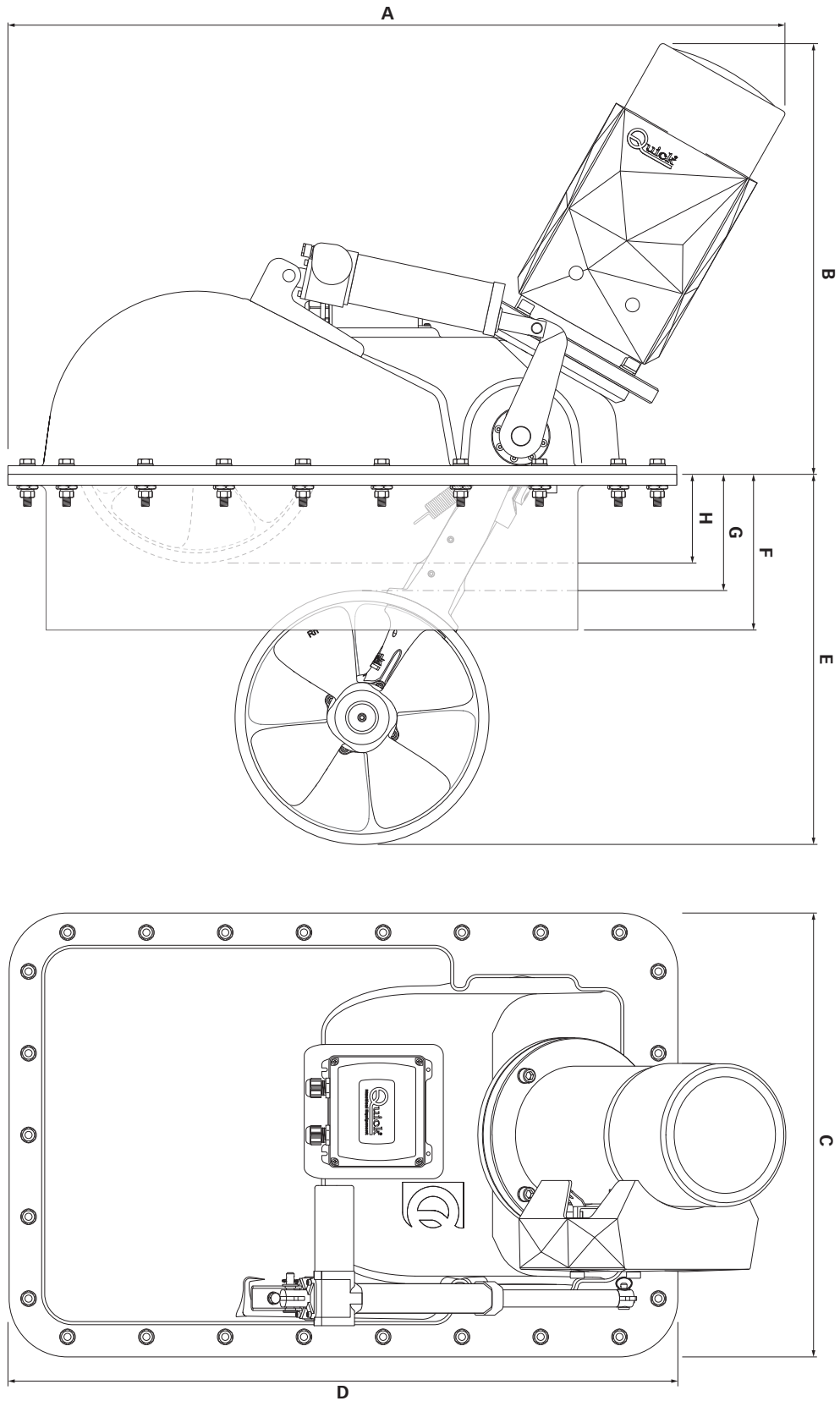
No.	DESCRIPTION	CODE
1A	OSP CONSTANT VELOCITY JOINT Ø140	FVSGG140BTR0A00
1B	OSP CONSTANT VELOCITY JOINT Ø185	FVSGG185BTR0A00
1C	OSP CONSTANT VELOCITY JOINT Ø250	FVSGG250BTR0A00
1D	OSP CONSTANT VELOCITY JOINT Ø300	FVSGG300BTR0A00
2A	OSP DIAMOND CASING 'A' KIT	FVSGCARBTQR1A00
2B	OSP DIAMOND CASING 'B' KIT	FVSGCARBTQR1B00
3A	OSP HINGE + SUPP. BRACKET KIT BTR140	FVSGCN140000A00
3B	OSP HINGE + SUPP. BRACKET KIT BTR185	FVSGCN185000A00
3C	OSP HINGE + SUPP. BRACKET KIT BTR250	FVSGCN250000A00
3D	OSP HINGE + SUPP. BRACKET KIT BTR300	FVSGCN300000A00
4A	OSP MOTOR 1500W 12V BTR 140+T	FVEMFEL1512B14T
4B	OSP MOTOR 2200W 12V BTR 140+T	FVEMFEL2212B14T
4C	OSP MOTOR 3300W12V BTR185+T	FVEMFEL3312B18T
4D	OSP MOTOR 3300W24V BTR185+T	FVEMFEL3324B18T
4E	OSP MOTOR 4300W12V BTR185+T	FVEMFEL4312B18T
4F	OSP MOTOR 4300W24V BTR185+T	FVEMFEL4324B18T
4G	OSP MOTOR 6300W12V BTR185+T	FVEMFEL6312B18T
4H	OSP MOTOR 6300W24V BTR185+T	FVEMFEL6324B18T
4I	OSP MOTOR 6500W 24V BTR250+T	FVEMFEL6524B25T
4J	OSP MOTOR 8000W 24V BTR250+T	FVEMFEL8024B25T
4K	OSP MOTOR 10KW 24V BTR250+T	FVEMFEL1K24B25T
4L	OSP MOTOR 10KW 24V BTR300+T	FVEMFEL1K24B30T
4M	OSP MOTOR 12KW 24V BTR300+T	FVEMFEL2K24B30T
4N	OSP MOTOR 15KW 48V BTR300+T	FVEMFEL5K48B30T
5A	OSP COMP. STAINLESS STEEL WIRE ROPE KIT BTR140	FVSBTR14000A00
5B	OSP COMP. STAINLESS STEEL WIRE ROPE KIT BTR185	FVSBTR18500A00
5C	OSP COMP. STAINLESS STEEL WIRE ROPE KIT BTR250	FVSBTR25000A00
5D	OSP COMP. STAINLESS STEEL WIRE ROPE KIT BTR300	FVSBTR30000A00
6A	OSP REV. CONTACTOR BOX KIT 150A 12V	FVSGRCT15012A00
6B	OSP REV. CONTACTOR BOX KIT 150A 24V	FVSGRCT15024A00
6C	OSP REV. CONTACTOR BOX KIT 350A 12V	FVSGRCT35012A00
6D	OSP REV. CONTACTOR BOX KIT 350A 24V	FVSGRCT35024A00
7	OSP THERMAL CUT-OUT KIT	FVKPS120BTR0A00
8A	OSP ACTUATOR 12V Ø140	FVEAL1401200000
8B	OSP ACTUATOR 12V Ø185	FVEAL1851200000
8C	OSP ACTUATOR 24V Ø185	FVEAL1852400000
8D	OSP ACTUATOR 24V Ø250	FVEAL2502400000
8E	OSP ACTUATOR 24V Ø300	FVEAL3002400000
8F	OSP ACTUATOR 48V Ø300	FVEAL3004800000
9A	OSP FLANGE KIT BTR140	FVEFGMBTR140000
9B	OSP FLANGE KIT BTR185	FVEFGMBTR185000
9C	OSP FLANGE KIT BTR250D00	FVEFGMBTR250000
9D	OSP FLANGE KIT BTR300	FVEFGMBTR300000
10A	OSP ANODES FOR PROPELLER KIT BTR185	FVSGANBTR18AA00
10B	OSP ANODES FOR PROPELLER KIT BTR250E00	FVSGANBTR25EA00
10C	OSP ANODES FOR PROPELLER KIT BTR300	FVSGANBTR30AA00
11C	OSP ANODES FOR PROPELLER KIT BTR140	FVSGANBTR14AA00
12A	OSP PROPELLER D185 LH QUICK 5 BLADES BLACK	FVSGEL185L05A00
12B	OSP BTR THRUSTER D250 LH QUICK 5 BLADES E00	FVSGEL250LE5A00
13A	OSP THRUSTER D185 RH QUICK 5 BLADES	FVSGEL185R05A00
13B	OSP THRUSTER D250 RH QUICK 5 BLADES E00	FVSGEL250RE5A00
13C	OSP THRUSTER KIT BTR 140 RH 5 BLADES	FVSGEL140R00A00
14	OSP THRUSTER KIT LH BTR 300	FVSGEL300L00A00
15	OSP THRUSTER KIT RH BTR 300	FVSGEL300R00A00
16	OSP GEARBOX KIT BTQ140	FVSGGBT1400A00
17A	OSP GEARBOX KIT BTQ185 DP	FVSGGBT185DA00
17B	OSP GEARBOX KIT BTR250 E00	FVSGGBT25EA00
17C	OSP GEARBOX KIT BTQ 300	FVSGGBT3000A00
18A	OSP HINGE VERT. FIX. ANGLE BRACKET BTR140	FVSLPVNG1400A00
18B	OSP HINGE VERT. FIX. ANGLE BRACKET BTR185	FVSLPVNG1850A00
18C	OSP HINGE VERT. FIX. ANGLE BRACKET BTR250	FVSLPVNG2500A00
18D	OSP HINGE VERT. FIX. ANGLE BRACKET BTR300	FVSLPVNG3000A00





BTR 140





generic image



BTR 185 Pag.30

MOD.	BTR1856512	BTR1856524	BTR1858512	BTR1858524	BTR18510512	BTR18510524
A	722 (28" 27/64)		743 (29" 1/4)	709 (27" 29/32)	801 (31" 17/32)	779 (30" 21/32)
B	300 (11" 13/16)		323 (12" 23/32)	287 (11" 5/16)	384 (15" 1/8)	361 (14" 7/32)
C	370 (14" 9/16)					
D	599 (23" 37/16)					
E	300 (11" 13/16)					
F	150 (5" 29/32)					
G	94 (3" 45/64)					
H	60 (2" 23/64)					

BTR 250 Pag.30

MOD.	BTR25012024	BTR25014024	BTR25024024
A	879 (34" 39/64)		908 (35" 3/4)
B	450 (17" 23/32)		515 (20" 9/32)
C	394 (15 33/64) with actuator: 411 (16 3/16)		
D	754 (29" 11/16)		
E	406 (15" 63/64)		
F	200 (7" 7/8)		
G	154.5 (6" 5/64)		
H	63.5 (2" 1/2)		

BTR 300 Pag.30

MOD.	BTR30025024	BTR30027024	BTR30030048
A	954 (37" 9/16)	975 (38" 3/8)	997 (39" 1/4)
B	462 (18" 3/16)	514 (20" 1/4)	553 (21" 3/4)
C	570 (22" 7/16)		
D	859 (33" 13/16)		
E	475 (18" 11/16)		
F	200 (7" 7/8)		
G	149 (5" 7/8)		
H	114 (4" 1/2)		

BTR Series

REV 001C

CE

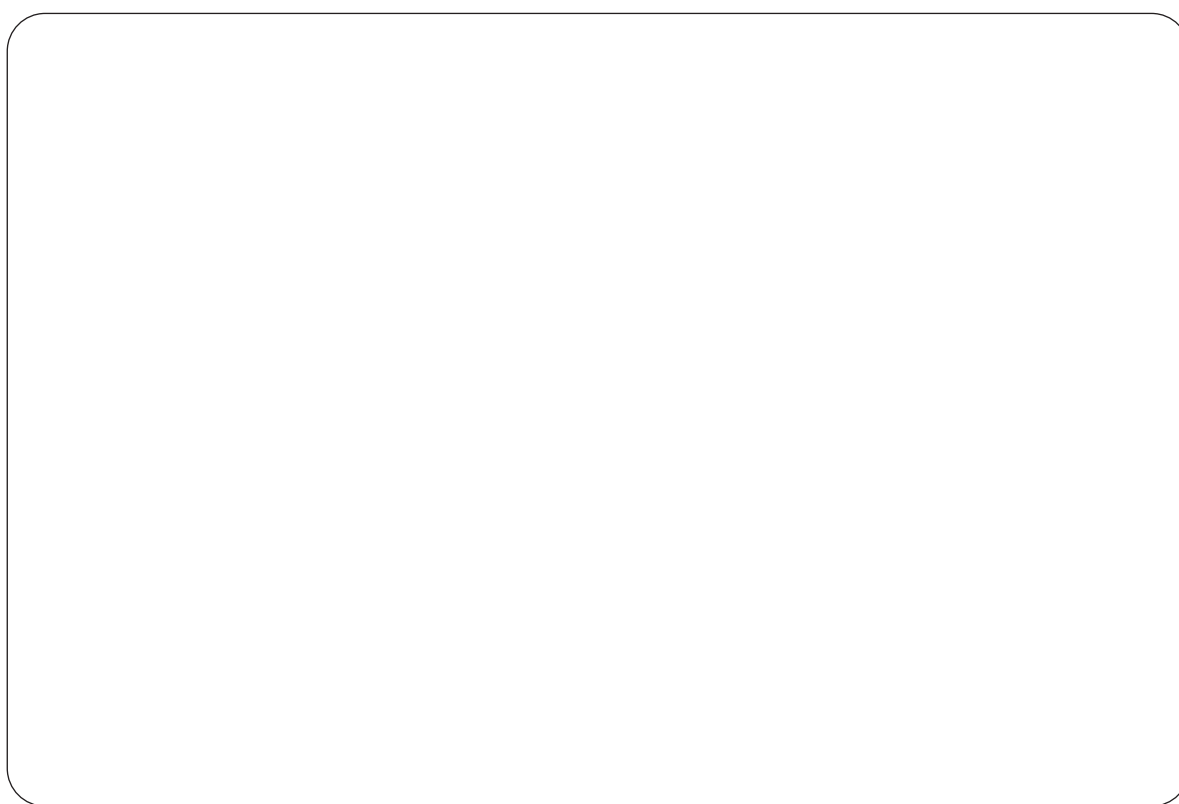
UK
CA

January, 2023

BTR 18585 - 185105

BTR 250150 - 250220

BTR 300240 - 300300 - 300400



Product serial number



QUICK® S.p.A. - Via Piangipane, 120/A - 48124 Piangipane (RAVENNA) - ITALY
Tel. +39.0544.415061 - Fax +39.0544.415047 - www.quickitaly.com - quick@quickitaly.com